

DO NOT SCALE PRINT

| ISSUE LET. | ALTERATIONS | CHANGE NO. | DATE |
|------------|-------------|------------|------|
|            |             |            |      |
|            |             |            |      |

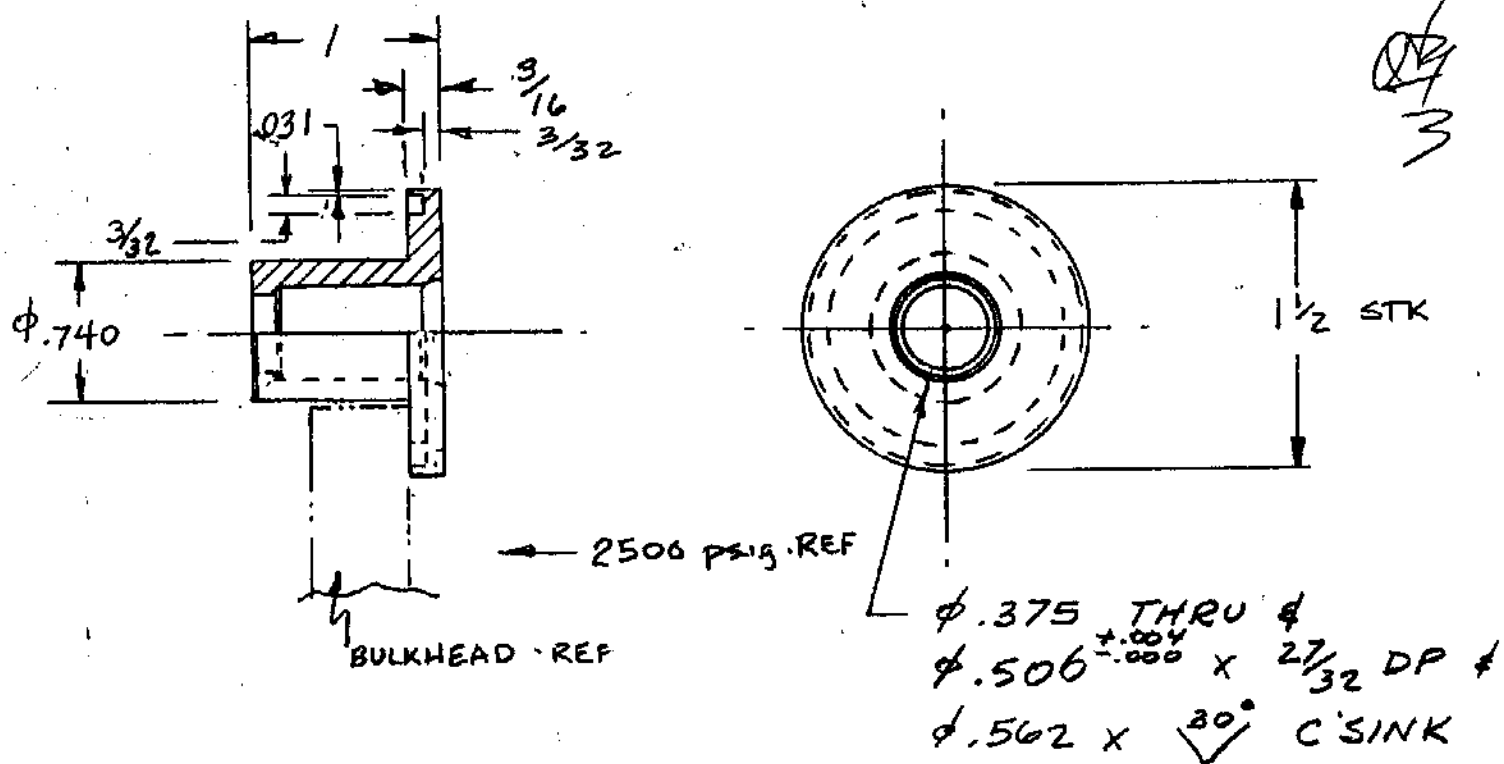

2. PAINT/FINISH AFTER T.I.G. WELDING - REF
1. MOUNTING BULKHEAD OPENING  $\phi .875$  MAX  $\phi .745$  MIN - REF
- NOTES:

|        |
|--------|
| SEAL   |
| FINISH |

ALL DIM. AND TOLERANCES APPLY TO FINISHED PART UNLESS OTHERWISE SPECIFIED.  
 ALLOWABLE TOLERANCES UNLESS OTHERWISE SPECIFIED -  
 FRACTIONS  $\pm 1/64$  DECIMALS  $\pm .005$  ANGLES  $\pm 1^\circ$

|                                   |                     |   |  |
|-----------------------------------|---------------------|---|--|
|                                   |                     | <b>PAVE Technology Co.</b><br>Pressure and Vacuum Electronics<br>Custom Hermetic Connectors |  |
| TITLE <b>FLANGED BUSHING WELD</b> |                     |   |  |
| MATERIAL <b>AISI C-1018 STEEL</b> |                     |   |  |
| DR. BY <i>WHL</i>                 | APPROVED BY         | DRAWN <b>TRANE</b>  |  |
| CHD BY                            | DATE <b>2/22/88</b> | SCALE <b>1/1</b>  |  |
| PART NUMBER <b>0146</b>           |                     |   |  |