

LEAK TEST PORT

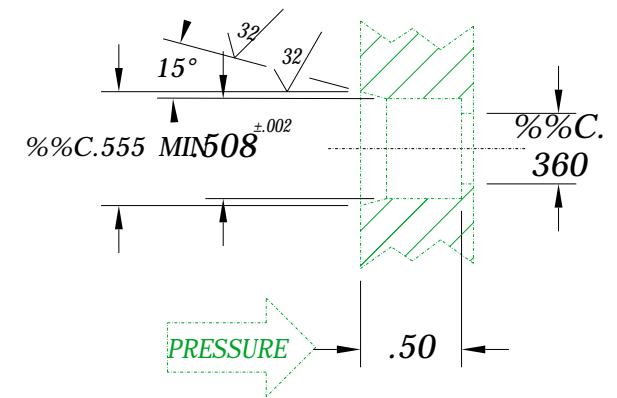

**NOTES:**

1. LEAK TEST: 300 PSI, NO BUBBLES 1 MINUTE MINIMUM.
2. HYPOT 630 VDC 500 MW .01 SEC MINIMUM, WIRE TO WIRE & HOUSING.
3. ALL TESTS ARE PERFORMED AT ROOM TEMPERATURE.
4. ALL SPECIFICATIONS AND TESTS SUPERSEDE PAVE CATALOG SPECIFICATIONS.

6	A/R	SUPER O-LUBE	LUBRICANT O-RING SILICONE BASED
5	1	-012 VITON	O-RING -012 VITON 75
4	A/R	PAVE-Seal 200	EPOXY BLACK
3	1@27"	E22 BLK	WIRE 22E MIL-W-16878/4 .010 7/#30
2	1@27"	E22 RED	WIRE 22E MIL-W-16878/4 .010 7/#30
1	1	1226-S	HOUSING SP8S-E
ITEM	QTY	PART NUMBER	DESCRIPTION

ALL DIMENSIONS AND TOLERANCES APPLY TO FINISHED PART IN INCHES  
 ALLOWABLE TOLERANCES UNLESS SPECIFIED OTHERWISE: NONE +/- .5  
 .X DECIMAL +/- .1 .XX DECIMAL +/- .02 .XXX DECIMAL +/- .005  
 ANGLES +/- 1 DEG SURFACE FINISH 128 microinch RMS

**PAVE technology co.**  
 2751 Thunderhawk Court  
 Dayton, Ohio 45414-3445  
 U.S.A.  
 (937)890-1100  
 fax (937)890-5165  
 www.pavetechnologyco.com

DESCRIPTION PAVE-Seal® Cable Harnesses

**SP8S-E-200-2-TE22-8-18**

PART NUMBER

**1977**

PROJECTION

