

SEE NOTE 1.

ATMOSPHERE PRESSURE

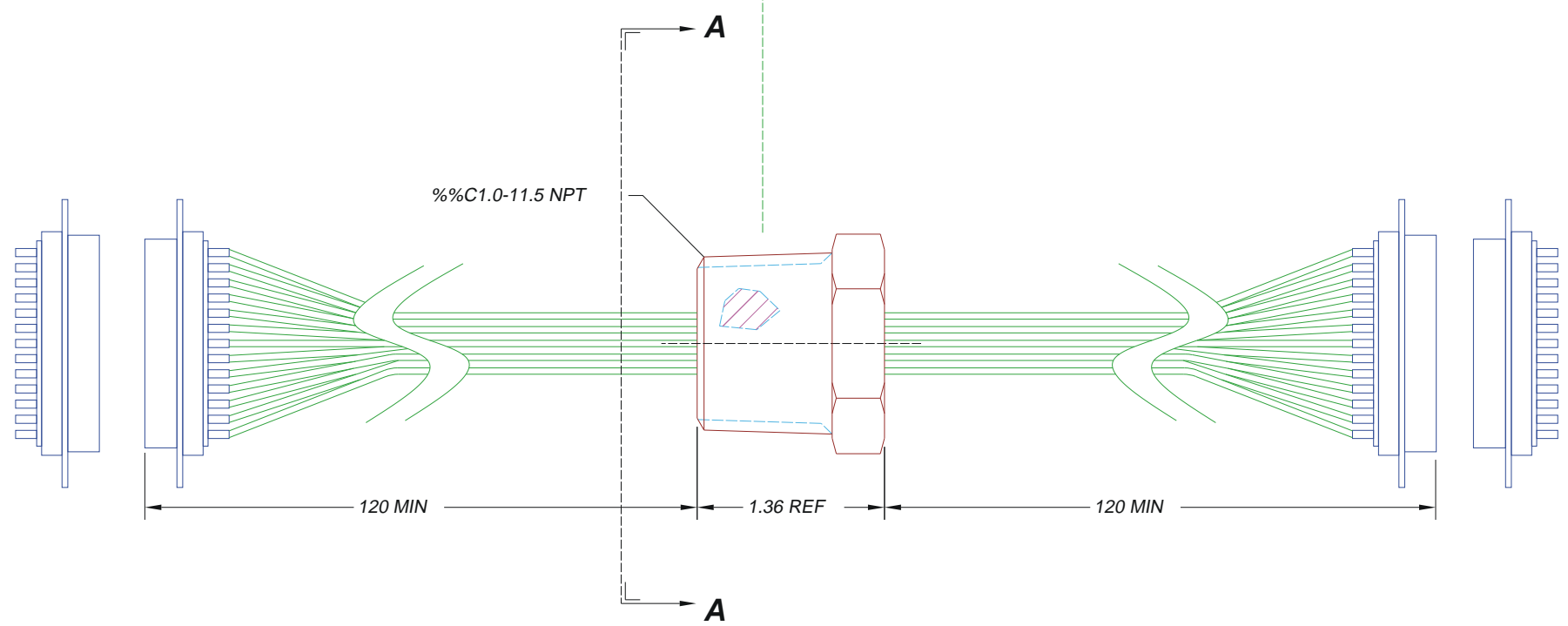
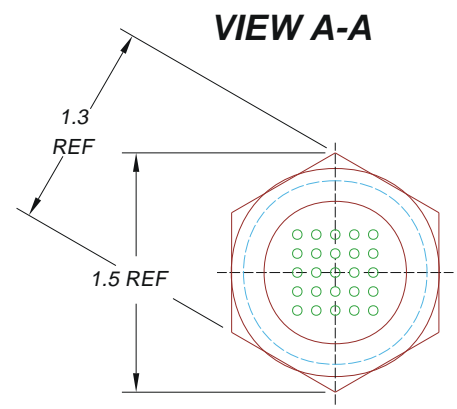

NOTES:

- 1. 80 PSI LEAK TEST, NO BUBBLES, 10 MINUTES MIN.
- 2. HYPOT 630 VDC 500 MEGOHMS .01 SEC MINIMUM, WIRE TO WIRE & HOUSING
- 3. CONTINUITY TEST: W/ MATING PLUGS <.1 OHMS PIN TO SOCKET
- 4. CUSTOMER APPLICATION - VACUUM THREAD SIDE.

TITLE OR PAVE ORDER CODE	
PT16-SS-80-25-PC22-120T-120T	
PART NUMBER	PROJECTION
1654	