

CARDBOARD SHIPPING VEHICLE
SCALE 1 = 5

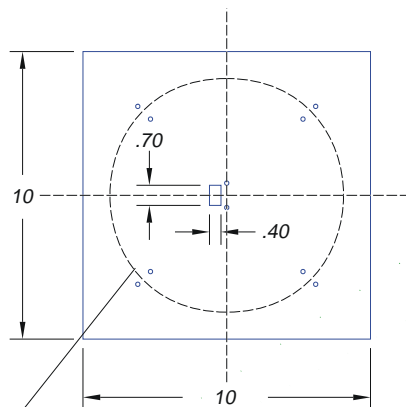

COIL FIBERS ~ 8; \varnothing
HOLD IN PLACE W/
WIRE TIES THROUGH BOARD

NOTES:

1. HE LEAK TEST @ 1 ATM. 10^{-6} CC/S.
2. CHECK OPTICAL CONTINUITY OF EACH FIBER.
3. ALL TESTS ARE PERFORMED AT ROOM TEMPERATURE.
4. ALL SPECIFICATIONS AND TESTS SUPERSEDE PAVE CATALOG SPECIFICATIONS.
5. PACK ONTO FLAT CARDBOARD WITH HOUSING TIED DOWN & FIBERS COILED AROUND.

7	3x98"	A-STT-30-50	TUBING .012"IDx.008"THK TEFLON
6	1	0894	NUT VS8-SS
5	A/R	SUPER O-LUBE	LUBRICANT O-RING SILICONE
4	1	-112 VITON	O-RING -112 VITON 75A
3	3x98"	CF04247-04	FIBER OPTICAL 5.1/125/245um
2	A/R	PAVE-Seal 150	EPOXY BLACK
1	1	0892	HOUSING VS8-SS

ITEM	QTY	PART#	DESCRIPTION
------	-----	-------	-------------

ALL DIMENSIONS AND TOLERANCES APPLY TO FINISHED PART IN INCHES
ALLOWABLE TOLERANCES UNLESS SPECIFIED OTHERWISE: NONE +/- .5
.X DECIMAL +/- .1 .XX DECIMAL +/- .02 .XXX DECIMAL +/- .005
ANGLES +/- 1 DEG SURFACE FINISH 128 microinch RMS



DESCRIPTION PAVE-Seal® Cable Harnesses
VS8-SS-150-3-SMFO-48-48

PART NUMBER
1955

