

ATMOSPHERE PRESSURE

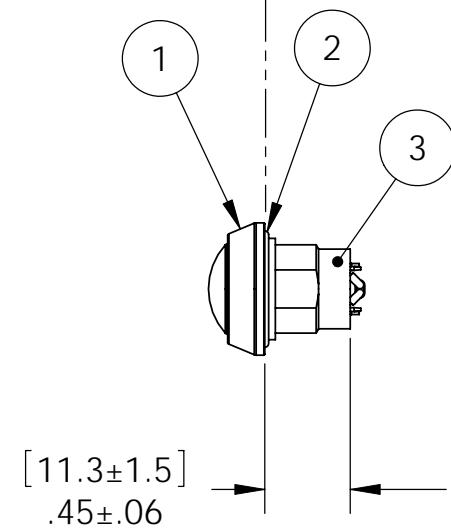

VS7 INSTALLATION PORT

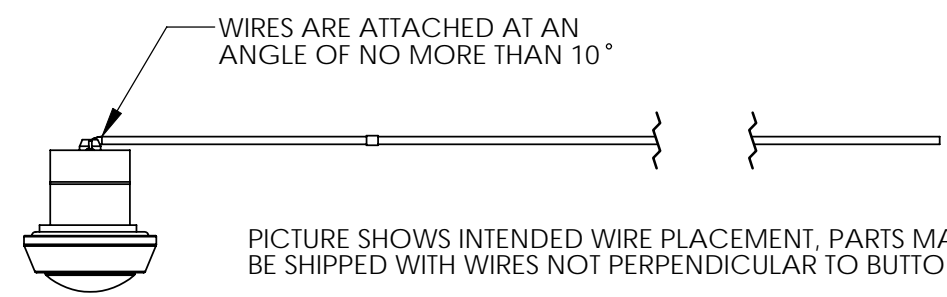
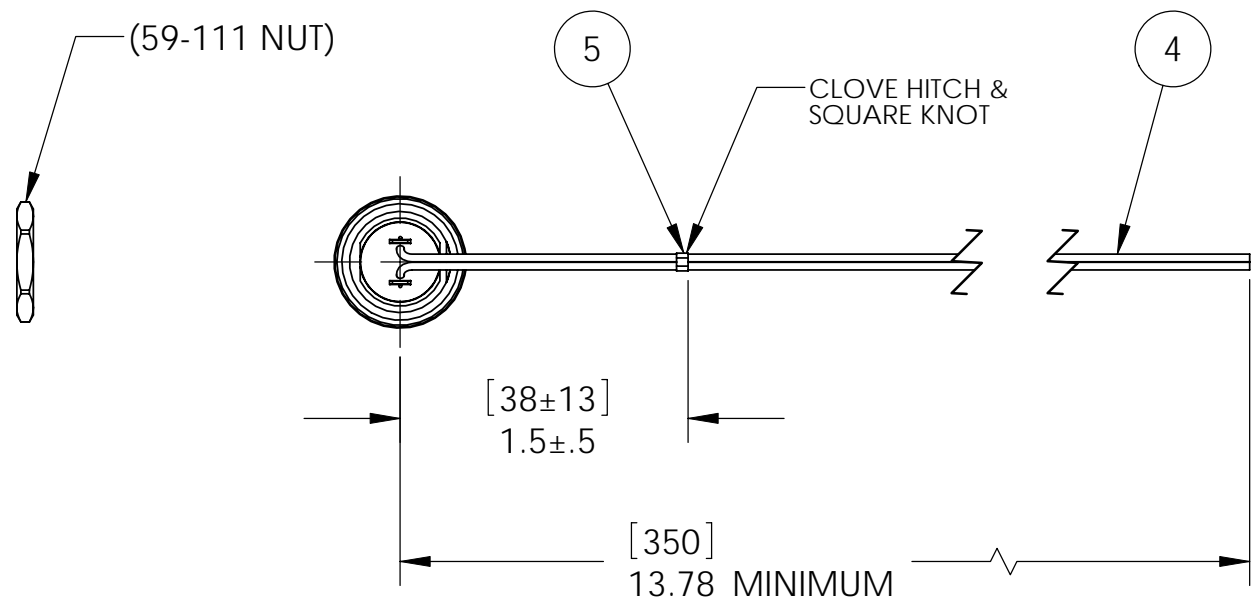
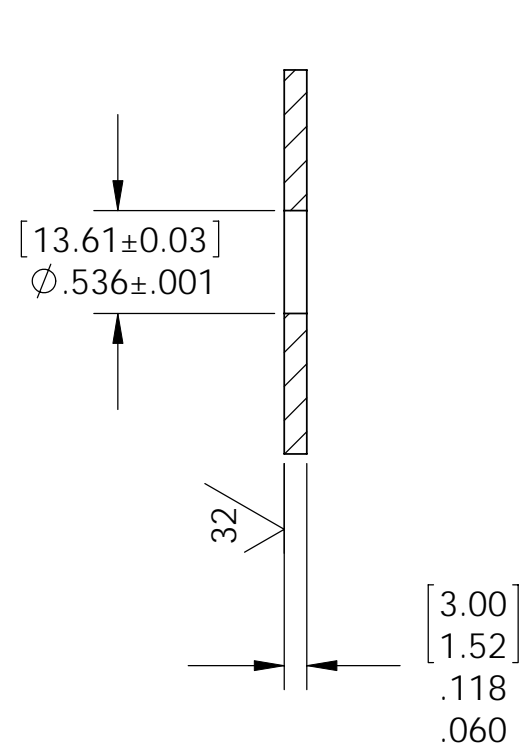

NOTES:

1. LEAK TEST: 8 PSI, NO BUBBLES 1 MINUTE MINIMUM (SAMPLE ONLY).
2. LEAK TEST IS PERFORMED AT ROOM TEMPERATURE.
3. WIRE POSITIONING IS APPROXIMATE & VARIABLE.
4. VOIDS LARGER THAN $\varnothing 0.035$ [.89] ARE NOT ACCEPTABLE.
5. DIMENSIONS ARE IN INCHES [millimeters].

5	1	A-A-52080-B-5	TAPE LACING NYLON FLT BRD WHT
4	2	TZ26WHITE	WIRE 26 TEFZEL M22759/32 19/#38
3	A/R	PAVE-Seal 150	EPOXY BLACK
2	1	5-566 N0674-70	O-RING 5-566 BUNA N0674-70 BLACK
1	1	59-111	PUSHBUTTON SEALED PANEL MINIATURE W/NUT
ITEM	QTY	PART NUMBER	DESCRIPTION

PAVE technology co.
 2751 Thunderhawk Court
 Dayton, OH 45414-3445
 U.S.A.
 tel (937) 890-1100
 fax (937) 8905165
 www.pavetechnologyco.com

DESCRIPTION
 VS7-ZA-80-2-TZ26-BUTTON-13.8

PART NUMBER
4155

MATERIAL NOTED

REVISION LEVEL -

PROJECTION

ALL DIMENSIONS AND TOLERANCES APPLY TO FINISHED PART IN INCHES.
 ALLOWABLE TOLERANCES UNLESS SPECIFIED OTHERWISE: NONE ±0.5
 X.X DECIMAL ±0.1 X.XX DECIMAL ±0.02 X.XXX DECIMAL ±0.005
 ANGLES ±1 DEGREE SURFACE FINISH 128 microinch RMS