

PIN #	WIRE COLOR
1	BLACK
2	BLUE
3	GREEN
4	ORANGE
5	RED
6	VIOLET
7	WHITE
8	YELLOW
9	GRAY
10	BROWN

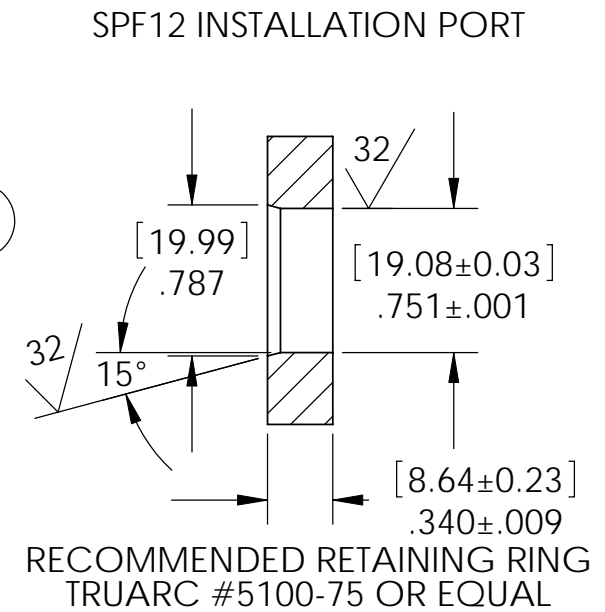
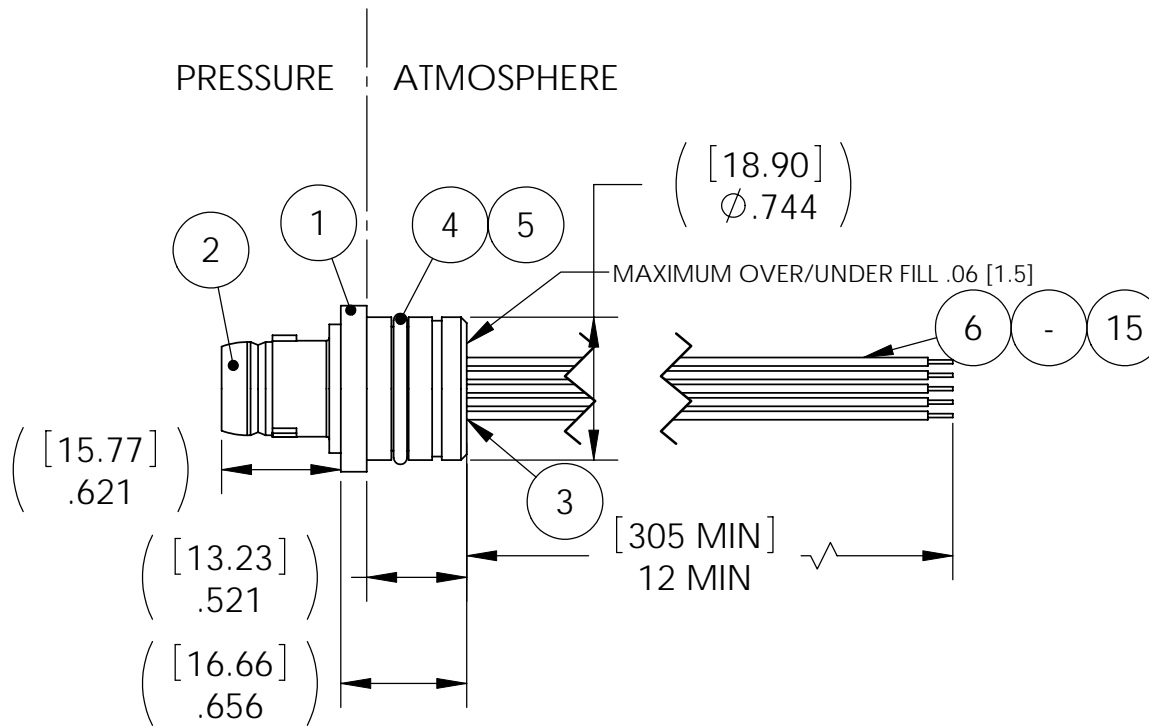
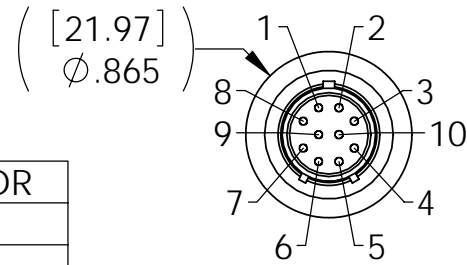

NOTES:

- LEAK TEST: 1500 PSI, NO BUBBLES 30 SECONDS MINIMUM.
- HYPOT 630 VDC 500 MEGOHMS MINIMUM 0.01 SECOND MINIMUM PINS TO PINS AND HOUSING WITH MATING CONNECTOR.
- CONTINUITY CHECK < .5 OHMS.
- ALL TESTS ARE PERFORMED AT ROOM TEMPERATURE.
- ALL PARTS MUST PASS ALL TESTS.
- VOIDS SMALLER THAN $\phi 0.035[.89]$ ARE ACCEPTABLE.
- REF-OPERATING TEMPERATURE -40°C TO 125°C .
- PAVE-SEAL CAN BE A BI-DIRECTIONAL HERMETIC SEAL FOR VACUUM AND MOST PRESSURES. FOR PRESSURES ABOVE 150 PSI (10 BAR), CHECK WITH SALES ENGINEERING.
- DIMENSIONS ARE INCHES [millimeters].
- MATING RECEPTACLE (ORDERED SEPARATELY) IS PART NUMBER 4251.

15	1	E24 BROWN	WIRE 24E MIL-W-16878/4 7/#32
14	1	E24 GRAY	WIRE 24E MIL-W-16878/4 7/#32
13	1	E24 YELLOW	WIRE 24E MIL-W-16878/4 7/#32
12	1	E24 WHITE	WIRE 24E MIL-W-16878/4 7/#32
11	1	E24 VIOLET	WIRE 24E MIL-W-16878/4 7/#32
10	1	E24 RED	WIRE 24E MIL-W-16878/4 7/#32
9	1	E24 ORANGE	WIRE 24E MIL-W-16878/4 7/#32
8	1	E24 GREEN	WIRE 24E MIL-W-16878/4 7/#32
7	1	E24 BLUE	WIRE 24E MIL-W-16878/4 7/#32
6	1	E24 BLACK	WIRE 24E MIL-W-16878/4 7/#32
5	A/R	SUPER O-LUBE	LUBRICANT O-RING SILICONE-BASED
4	1	-016 FLUORO	O-RING -016 FLUOROSILICONE 70
3	A/R	PAVE-Seal 150	EPOXY BLACK
2	1	4250 PLUG	PLUG PUSH-PULL 10 #20 PINS
1	1	4274	HOUSING SPF12-AL
ITEM	QTY.	PART #	DESCRIPTION

ALL DIMENSIONS AND TOLERANCES APPLY TO FINISHED PART IN INCHES.
ALLOWABLE TOLERANCES UNLESS SPECIFIED OTHERWISE: NONE ± 0.5
X.X DECIMAL ± 0.1 X.XX DECIMAL ± 0.02 X.XXX DECIMAL ± 0.005
ANGLES ± 1 DEGREE SURFACE FINISH 128 microinch RMS

PAVE technology co.
2751 Thunderhawk Court
Dayton, OH 45414-3445
U.S.A.
tel (937) 890-1100
fax (937) 8905165
www.pavetechnologyco.com

DESCRIPTION
SPF12-AL-150-10-TE24-MMPPP-12

PART NUMBER
4250

MATERIAL NOTED

REVISION LEVEL
D

PROJECTION