

1821-1	24 [609.6]
1821	12 [304.8]
PART #	X

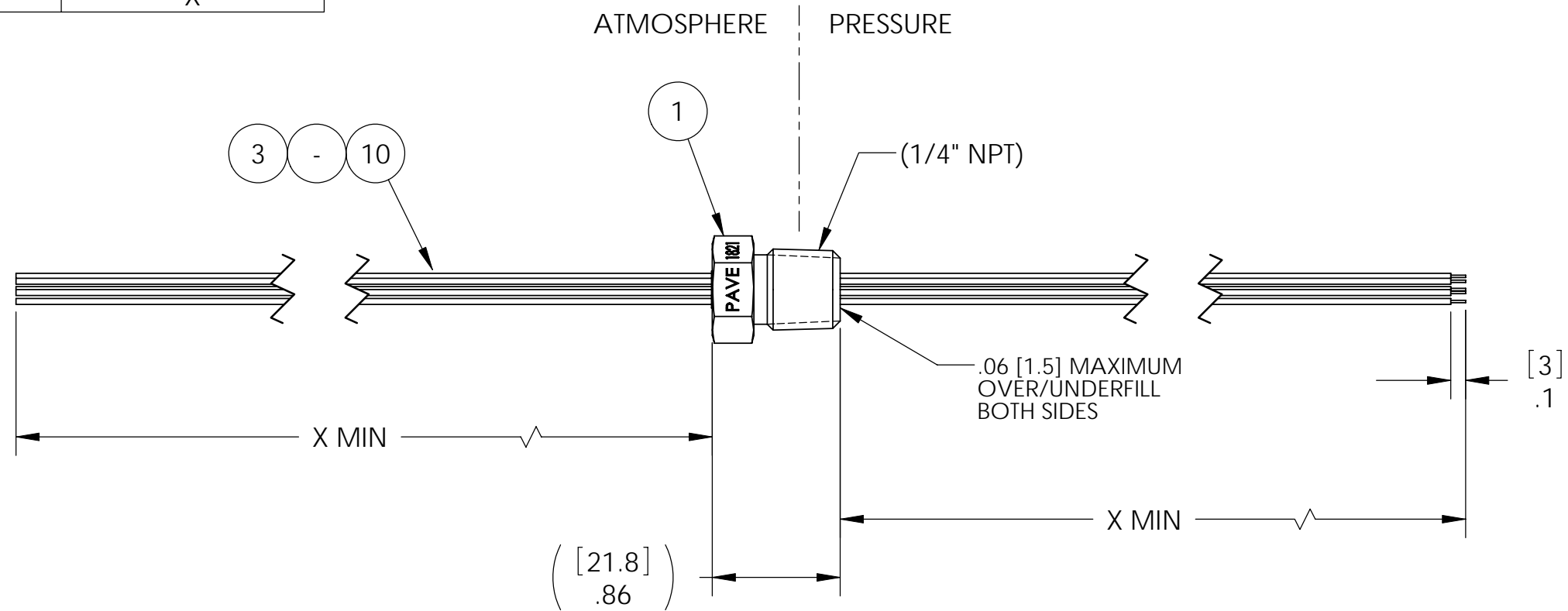
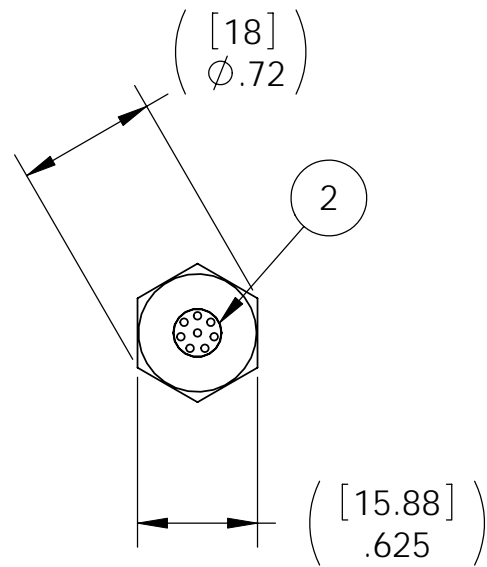

NOTES:

1. LEAK TEST: 80 PSI, NO BUBBLES 1 MINUTE MINIMUM. QUALIFICATION ONLY: 1000 PSI, NO BUBBLES 30 SECONDS MINIMUM.
2. HYPOT 630 VDC 500 MEGOHMS MINIMUM 0.01 SECOND MINIMUM WIRE TO WIRE AND HOUSING.
3. ALL TESTS ARE PERFORMED AT ROOM TEMPERATURE.
4. ALL PARTS MUST PASS ALL TESTS.
5. WIRE POSITIONING IS APPROXIMATE & COLOR POSITIONS ARE VARIABLE.
6. VOIDS LARGER THAN  $\phi 0.035$  [.89] ARE NOT ACCEPTABLE.
7. REF-OPERATING TEMPERATURE -20 °C TO 125 °C.
8. DIMENSIONS ARE INCHES [millimeters].
9. PAVE-SEAL CAN BE A BI-DIRECTIONAL HERMETIC SEAL FOR VACUUM AND MOST PRESSURES. FOR PRESSURES ABOVE 150 PSI (10 BAR), CHECK WITH SALES ENGINEERING.

10	1	E26 YELLOW	WIRE 26E MIL-W-16878/4 7/#34
9	1	E26 WHITE	WIRE 26E MIL-W-16878/4 7/#34
8	1	E26 RED	WIRE 26E MIL-W-16878/4 7/#34
7	1	E26 ORANGE	WIRE 26E MIL-W-16878/4 7/#34
6	1	E26 GRAY	WIRE 26E MIL-W-16878/4 7/#34
5	1	E26 BROWN 7STRD	WIRE 26E MIL-W-16878/4 7/#34
4	1	E26 BLUE	WIRE 26E MIL-W-16878/4 7/#34
3	1	E26 BLACK 7STRD	WIRE 26E MIL-W-16878/4 7/#34
2	A/R	PAVE-Seal 150	EPOXY BLACK
1	1	1592	HOUSING PT4-SS
ITEM	QTY	PART NUMBER	DESCRIPTION

**PAVE technology co.**  
 2751 Thunderhawk Court  
 Dayton, OH 45414-3445  
 U.S.A.  
 tel (937) 890-1100  
 fax (937) 8905165  
 www.pavetechnologyco.com

DESCRIPTION  
 PT4-SS-150-8-TE26-12-12

PART NUMBER  
**1821**

MATERIAL NOTED

REVISION LEVEL  
 B

PROJECTION

ALL DIMENSIONS AND TOLERANCES APPLY TO FINISHED PART IN INCHES.  
 ALLOWABLE TOLERANCES UNLESS SPECIFIED OTHERWISE: NONE  $\pm 0.5$   
 X.X DECIMAL  $\pm 0.1$  X.XX DECIMAL  $\pm 0.02$  X.XXX DECIMAL  $\pm 0.005$   
 ANGLES  $\pm 1$  DEGREE SURFACE FINISH 128 microinch RMS