

VS15L INSTALLATION PORT

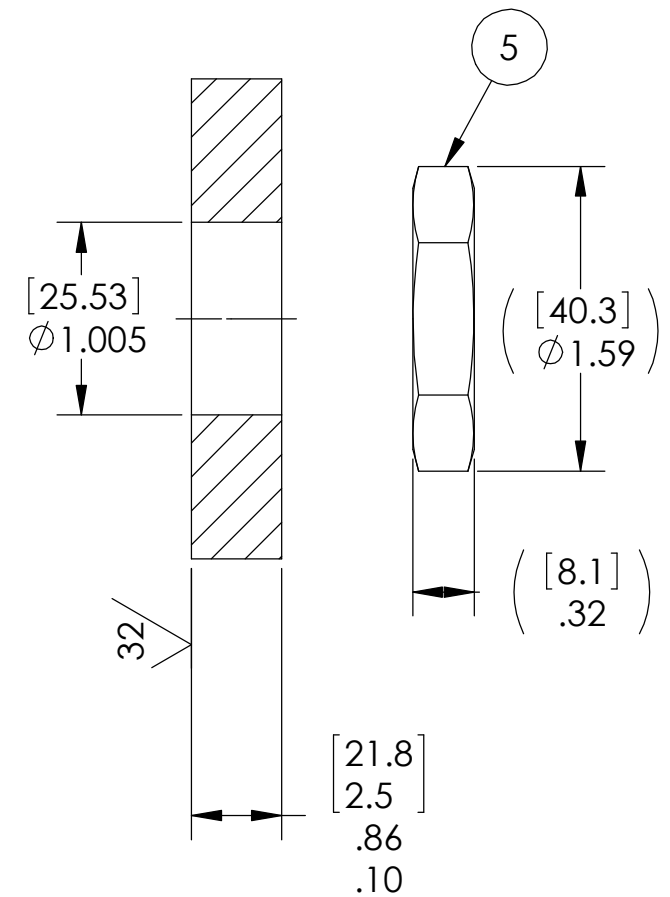

NOTES:

1. HE LEAK TEST @ 1 ATM. 1X10⁻⁶ CC/SEC OR LESS. A GREEN PAINT DOT ON THE ATMOSPHERE SIDE INDICATES THE PART HAS PASSED THE TEST.
2. HYPOT 630 VDC 500 MEGOHMS MINIMUM 0.01 SECOND MINIMUM WIRE TO WIRE AND HOUSING.
3. ALCOHOL OR FOMBLIN YVAC 3 MAY BE USED TO LUBRICATE O-RINGS FOR VACUUM HELIUM LEAK TESTING.
4. ALL TESTS ARE PERFORMED AT ROOM TEMPERATURE.
5. ALL PARTS MUST PASS ALL TESTS.
6. WIRE POSITIONING IS APPROXIMATE & VARIABLE.
7. COSMETIC SURFACE VOIDS NOT ON O-RING SEALING SURFACES ARE ACCEPTABLE BASED ON THE SEAL'S DIAMETER:
 <= .5 [12.7] SEAL DIAMETER: Ø.035 [.89] MAX ALLOWED VOID SIZE
 > .5 [12.7] SEAL DIAMETER: Ø.060 [1.5] MAX ALLOWED VOID SIZE
8. REF-OPERATING TEMPERATURE RANGE -40°C TO 125°C.
9. DIMENSIONS ARE INCHES [millimeters].
10. PAVE-SEAL CAN BE A BI-DIRECTIONAL HERMETIC SEAL FOR VACUUM AND MOST PRESSURES. FOR PRESSURES ABOVE 150 PSI (10 BAR), CHECK WITH SALES ENGINEERING.

| 5 | 1 | 0183 | NUT VS15-SS |
|------|-----|---------------|---------------------------------|
| 4 | 1 | -215 VITON LT | O-RING -215 VITON LOW-TEMP 75 |
| 3 | 9 | RXT20 | CABLE T/C 20 TYPE RX TEFLON PFA |
| 2 | A/R | PAVE-Seal 150 | EPOXY BLACK |
| 1 | 1 | 0161 | HOUSING VS15L-SS |
| ITEM | QTY | PART NUMBER | DESCRIPTION |

PAVE technology co.

2751 Thunderhawk Court
Dayton, OH 45414-3445
U.S.A.
tel (937) 890-1100
fax (937) 8905165
www.pavetechnologyco.com

DESCRIPTION
VS15L-SS-150-9P-RXT20-48-48

PART NUMBER
1875

MATERIAL NOTED

REVISION LEVEL
A

PROJECTION

ALL DIMENSIONS AND TOLERANCES APPLY TO FINISHED PART IN INCHES.
 ALLOWABLE TOLERANCES UNLESS SPECIFIED OTHERWISE: NONE ±0.5
 X.X DECIMAL ±0.1 X.XX DECIMAL ±0.02 X.XXX DECIMAL ±0.005
 ANGLES ±1 DEGREE SURFACE FINISH 128 microinch RMS