

PAVE#	"X"	"Y"
1708	10 [254]	1
1708-1	24 [610]	2

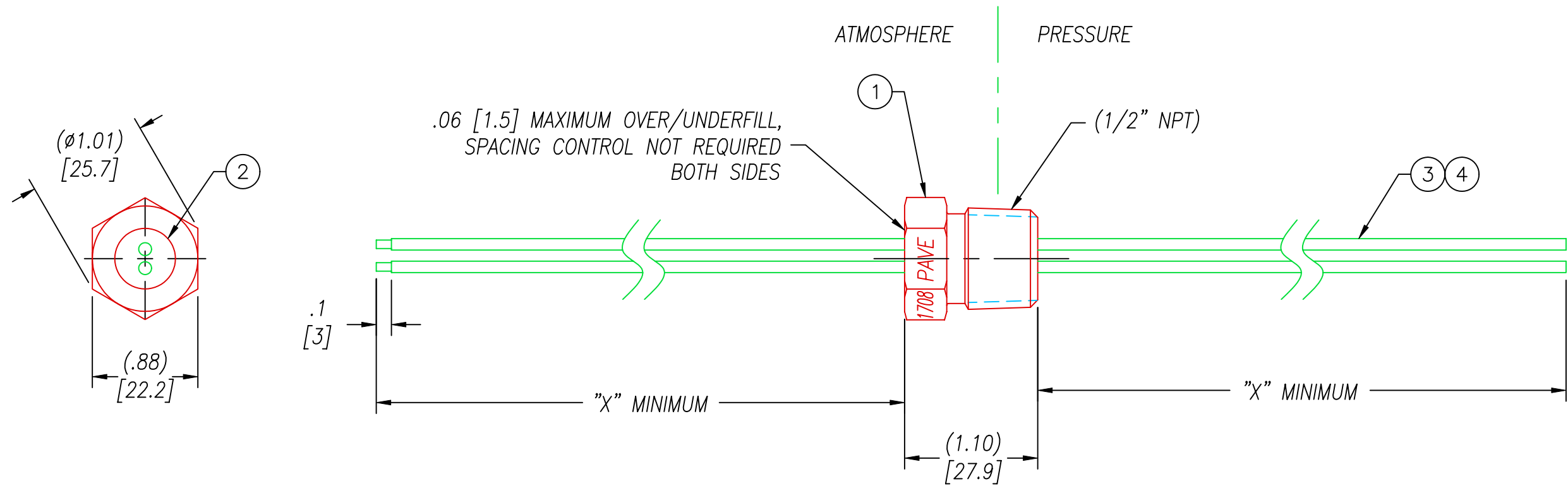

NOTES:

1. LEAK TEST: 80 PSI, NO BUBBLES "Y" MINUTES MINIMUM.
2. HYPOT 630 VDC 500 MΩ 0.01 SEC MINIMUM, WIRE TO WIRE & HOUSING.
3. ALL TESTS ARE PERFORMED AT ROOM TEMPERATURE.
4. ALL PARTS MUST PASS ALL TESTS.
5. WIRES ARE NOT REQUIRED TO BEND SHARPLY AT EPOXY SEAL SURFACE.
6. NO VOIDS LARGER THAN $\phi 0.035$ [0.89] ARE ACCEPTABLE.
7. REF-OPERATING TEMPERATURE RANGE -20°C TO 125°C .
8. DIMENSIONS ARE INCHES [millimeters].
9. PAVE-SEAL CAN BE A BI-DIRECTIONAL HERMETIC SEAL FOR VACUUM AND MOST PRESSURES. FOR PRESSURES ABOVE 150 PSI (10 BAR), CHECK WITH SALES ENGINEERING.

4	1	EE14 YELLOW	WIRE 14EE MIL-W-16878/5 19/#27 .017
3	1	EE14 BLACK	WIRE 14EE MIL-W-16878/5 19/#27 .017
2	A/R	PAVE-Seal 150	EPOXY BLACK
1	1	0346	HOUSING PT8-SS
ITEM	QTY	PART#	DESCRIPTION

ALL DIMENSIONS AND TOLERANCES APPLY TO FINISHED PART IN INCHES
 ALLOWABLE TOLERANCES UNLESS SPECIFIED OTHERWISE: NONE ± 0.5
 .X DECIMAL ± 0.1 .XX DECIMAL ± 0.02 .XXX DECIMAL ± 0.005
 ANGLES ± 1 DEG SURFACE FINISH 128 microinch RMS

 2751 Thunderhawk Court
 Dayton, Ohio 45414-3445
 U.S.A.
 (937)890-1100
 fax (937)890-5165
 www.pavetechnologyco.com

DESCRIPTION PAVE-Seal® Cable Harnesses
PT8-SS-150-2-TEE14-X-X

PART NUMBER	*SEE TABLE	REVISION LEVEL	A
1708*		PROJECTION	