

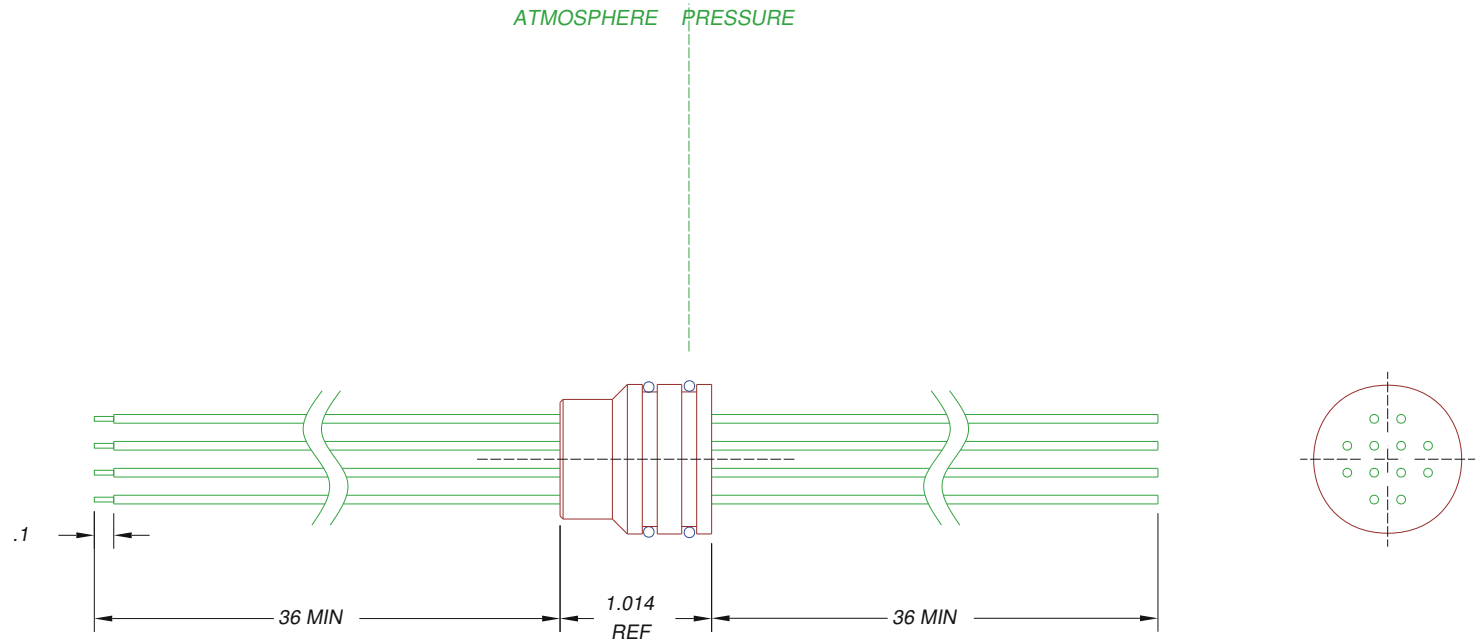

LEAK TEST PORT

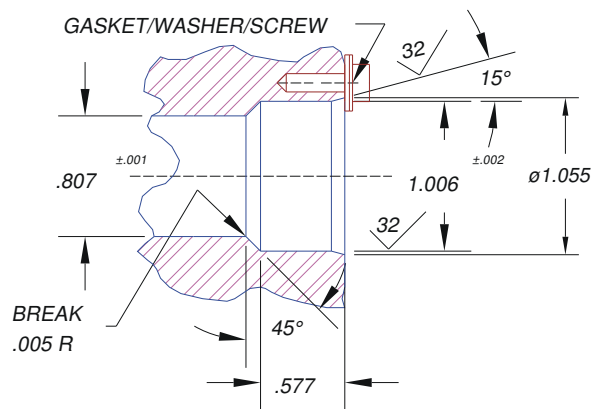

NOTES:

1. LEAK TEST: 80 PSI, NO BUBBLES 3 MINUTES MIN.
2. HYPOT 630 VDC 500 MEGOHMS .01 SEC MINIMUM, WIRE TO WIRE

		2751 Thunderhawk Court Dayton, Ohio 45414-3445 U.S.A. (937)890-1100 fax (937)890-5165 www.pavetechnologyco.com	
		TITLE OR PAVE ORDER CODE SP16-E-150-12-TE20-36-36	
PART NUMBER 1719	PROJECTION 