

LEAK TEST PORT

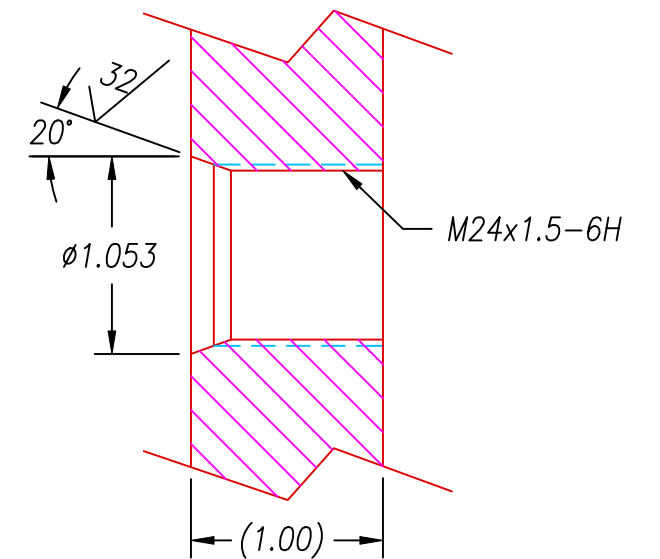

NOTES:

1. LEAK TEST: 450 PSI, NO N2 BUBBLES 6 MINUTES MINIMUM.
2. HYPOT 630 VDC 500 MΩ 0.01 SEC MINIMUM, WIRE TO WIRE.
3. ALL TESTS ARE PERFORMED AT ROOM TEMPERATURE.
4. PERCENTAGE OF PARTS TESTED WILL BE 100% (MAY BE A LESSER PERCENTAGE FOR LARGE PRODUCTION QUANTITIES, UNLESS OTHERWISE NOTED OR REQUIRED).
5. WIRES ARE NOT REQUIRED TO BEND SHARPLY AT EPOXY SEAL SURFACE.
6. NO VOIDS LARGER THAN Ø0.035 ARE ACCEPTABLE.

14	A/R	PARKER O-LUBE	LUBRICANT O-RING BARIUM-BASED
13	1	-117 VITON	O-RING -117 VITON 75
12	13"	E22 BLACK	WIRE 22E MIL-W-16878/4 .010 7/#30
11	13"	E22 WHT	WIRE 22E MIL-W-16878/4 .010 7/#30
10	13"	E22 GRAY	WIRE 22E MIL-W-16878/4 .010 7/#30
9	13"	E22 VIOLET	WIRE 22E MIL-W-16878/4 .010 7/#30
8	31"	E22 BLUE 7 STR	WIRE 22E MIL-W-16878/4 .010 7/#30
7	31"	E22 GREEN	WIRE 22E MIL-W-16878/4 .010 7/#30
6	13"	E22 YELLOW	WIRE 22E MIL-W-16878/4 .010 7/#30
5	13"	E22 ORANGE	WIRE 22E MIL-W-16878/4 .010 7/#30
4	151"	E22 RED	WIRE 22E MIL-W-16878/4 .010 7/#30
3	151"	E22 BROWN	WIRE 22E MIL-W-16878/4 .010 7/#30
2	A/R	PAVE-Seal 150FR	EPOXY BLACK FR
1	1	1201	HOUSING M24x1.5-V
ITEM	QTY	PART#	DESCRIPTION

ALL DIMENSIONS AND TOLERANCES APPLY TO FINISHED PART IN INCHES  
 ALLOWABLE TOLERANCES UNLESS SPECIFIED OTHERWISE: NONE +/-0.5  
 .X DECIMAL +/- 0.1 .XX DECIMAL +/- 0.02 .XXX DECIMAL +/-0.005  
 ANGLES +/- 1 DEG SURFACE FINISH 128 microinch RMS

 2751 Thunderhawk Court  
 Dayton, Ohio 45414-3445  
 U.S.A.  
 (937)890-1100  
 fax (937)890-5165  
 www.pavetechnologyco.com

DESCRIPTION PAVE-Seal® Cable Harnesses  
 M24-V-150-2/2/6-TE22-6-144/24/6

PART NUMBER  
 1731

REVISION LEVEL B  
 PROJECTION