

WIRE BUNDLE MUST EXIT WITHIN THE ϕ .620 ID OF A MATING FITTING

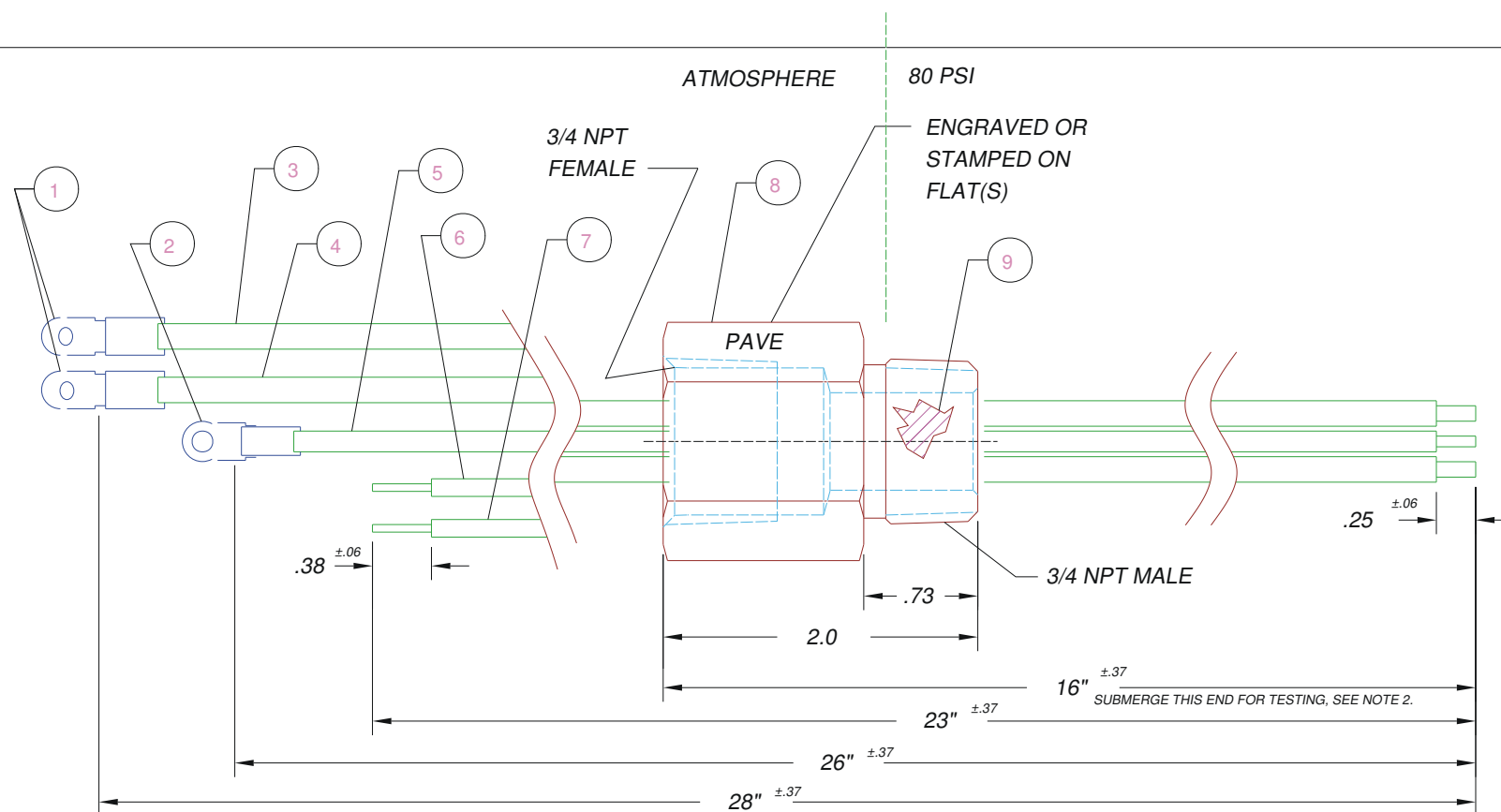
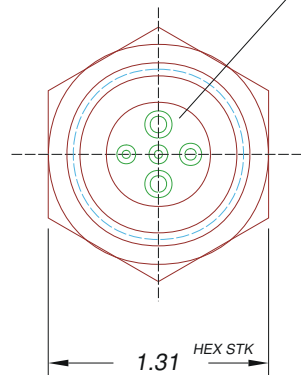

NOTES:

1. LEAK TEST: 80 PSI, NO BUBBLES 2 MINUTES MIN.
2. HYPOT 630 VDC 500 MEGOHMS .01 SEC MINIMUM, WIRE TO WIRE & HOUSING, NOTED END SUBMERGED IN SALT WATER.
3. CHECK CONTINUITY OF WIRES, LESS THEN 1.0 OHMS.
4. REF-OPERATING RANGE -40°C TO +90. REF-OPERATING RANGE -40°C.
5. FEMALE PIPE THREADS TO BE FREE OF EPOXY.

9	1	PAVESeal 200 FR	EPOXY FLAME RETARDENT
8	1	1789	HOUSING PTNF12-SS 316SS
7	1@23"	PCC18 RED	WIRE 18PVC UL1015 THK WALL RED
6	1@23"	PCC18 BLACK	WIRE 18PVC UL1015 THK WALL BLACK
5	1@26"	PCC14 GREEN	WIRE 14PVC UL1015 THK WALL GREEN
4	1@28"	PCC12 BLACK	WIRE 12PVC UL1015 THK WALL BLACK
3	1@28"	PCC12 WHITE	WIRE 12PVC UL1015 THK WALL WHITE
2	1	AMP #34160	TERMINAL RING 16-14 8 BLUE
1	2	AMP #34852	TERMINAL RING 12-10 6 YELLOW
ITEM	QTY	PART#	DESCRIPTION



TITLE OR PAVE ORDER CODE
PTNF12-SS-200FR-2/1/2-PCC12/14/18-*14

PART NUMBER
1788

