

LEAK TEST PORT

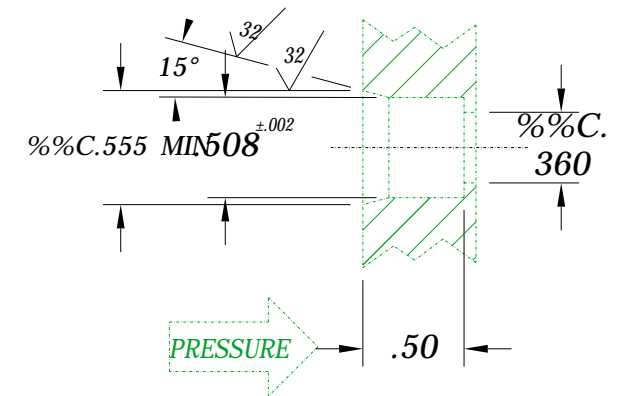

**NOTES:**

1. LEAK TEST: 300 PSI, NO BUBBLES 1 MINUTE MINIMUM.
2. HYPOT 630 VDC 500 MW .01 SEC MINIMUM, WIRE TO WIRE & HOUSING.
3. ALL TESTS ARE PERFORMED AT ROOM TEMPERATURE.
4. ALL SPECIFICATIONS AND TESTS SUPERSEDE PAVE CATALOG SPECIFICATIONS.

5	A/R	SUPER O-LUBE	LUBRICANT O-RING SILICONE BASED
4	1	-012 VITON	O-RING -012 VITON 75
3	A/R	PAVE-Seal 200	EPOXY BLACK
2	5@27"	E30 VIOLET	WIRE 30E 7/#38 .032"DIA
1	1	1226-S	HOUSING SP8S-E
ITEM	QTY	PART NUMBER	DESCRIPTION

ALL DIMENSIONS AND TOLERANCES APPLY TO FINISHED PART IN INCHES  
 ALLOWABLE TOLERANCES UNLESS SPECIFIED OTHERWISE: NONE +/- .5  
 .X DECIMAL +/- .1 .XX DECIMAL +/- .02 .XXX DECIMAL +/- .005  
 ANGLES +/- 1 DEG SURFACE FINISH 128 microinch RMS

**PAVE Technology Co.**  
 2751 Thunderhawk Court  
 Dayton, Ohio 45414-3445  
 U.S.A.  
 (937)890-1100  
 fax (937)890-5165  
 www.pavetechnologyco.com

DESCRIPTION PAVE-Seal® Cable Harnesses  
**SP8S-E-200-5-TE30-8-18**

PART NUMBER

**1978**

PROJECTION

