

LEAK TEST PORT

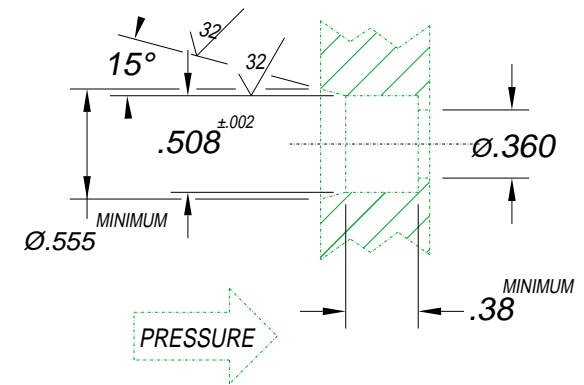

**NOTES:**

1. LEAK TEST: 3000 PSI, NO BUBBLES 30 SECONDS MIN.
2. HYPOT 630 VDC 500 MEGOHMS .01 SEC MINIMUM, WIRE TO WIRE.
3. ALL TESTS ARE DONE AT ROOM TEMPERATURE.
4. THESE SPECIFICATIONS SUPERSEDE PAVE CATALOG.

4	1	-012 BUNA	O-RING -012 BUNA 75
3	A/R	SUPER O-LUBE	LUBRICANT O-RING SILICONE BASED
2	2@13	E28 BLACK	WIRE 28E MIL-W-16878/4 .010 7/#36
1	1	1226-S	HOUSING SP8S-E
ITEM	QTY	PART NUMBER	DESCRIPTION

ALL DIMENSIONS AND TOLERANCES APPLY TO FINISHED PART IN INCHES  
 ALLOWABLE TOLERANCES UNLESS SPECIFIED OTHERWISE: NONE +/- .5  
 .X DECIMAL +/- .1 .XX DECIMAL +/- .02 .XXX DECIMAL +/- .005  
 ANGLES +/- 1 DEG SURFACE FINISH 128 microinch RMS



2751 Thunderhawk Court  
 Dayton, Ohio 45414-3445  
 U.S.A.  
 (937)890-1100  
 fax (937)890-5165  
 www.pavetechnologyco.com

DESCRIPTION *PAVE-Seal@ Cable Harnesses*

**SP8S-E-150-2-TE28-6-6**

PART NUMBER

**2058**

PROJECTION

