

VS12 INSTALLATION PORT

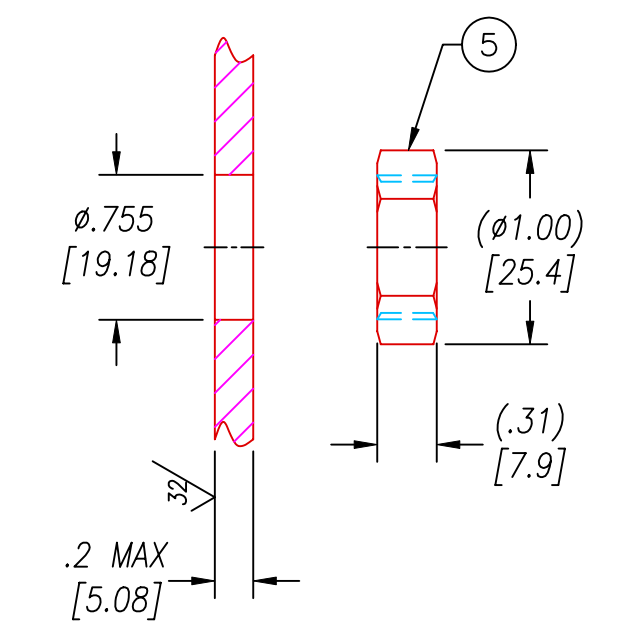

WASHERS & NUTS
REMOVED FOR CLARITY
IN THIS VIEW

- NOTES:
1. HE LEAK TEST @1 ATM. 10×10^{-9} CC/S OR LESS.
 2. HYPOT 630 VDC 500 MΩ 0.01 SEC MINIMUM, ROD TO HOUSING.
 3. ALL TESTS ARE PERFORMED AT ROOM TEMPERATURE.
 4. ALL PARTS MUST PASS ALL TESTS.
 5. NO VOIDS LARGER THAN $\phi.035$ [0.89] ARE ACCEPTABLE.
 6. DIMENSIONS ARE INCHES [millimeters].

7	4	BRASS WASH 1/4"	WASHER BRASS ID .260 OD .6875 THK .051
6	4	BRASS NUTS 1/4"	NUT BRASS WAF 7/16 THK 7/32
5	1	8L5N-SS NUT	NUT VS12-SS
4	1	-116 VITON	O-RING -116 VITON 75
3	A/R	PAVE-Seal 200	EPOXY BLACK
2	1	0221-1	ROD .25"DIA COPPER 75 AMP
1	1	1156	HOUSING VS12-SS
ITEM	QTY	PART#	DESCRIPTION

ALL DIMENSIONS AND TOLERANCES APPLY TO FINISHED PART IN INCHES
ALLOWABLE TOLERANCES UNLESS SPECIFIED OTHERWISE: NONE +/-0.5
.X DECIMAL +/- 0.1 .XX DECIMAL +/- 0.02 .XXX DECIMAL +/-0.005
ANGLES +/- 1 DEG SURFACE FINISH 128 microinch RMS

2751 Thunderhawk Court
Dayton, Ohio 45414-3445
U.S.A.
(937)890-1100
fax (937)890-5165
www.pavetechnologyco.com

PAVE technology co.

DESCRIPTION
VS12-SS-200-1-.25CU-3-3

PART NUMBER
0916

REVISION LEVEL
D

PROJECTION
⊙ ◁