

SEE NOTE 6

PRESSURE | ATMOSPHERE

(M24X1.5-6g)

.04 [1.0] MAXIMUM OVER/UNDERFILL

(.71) [18.0]

(.08) [2.0]

(.20) [5.0]

(1.02) [26.0]

X

Y

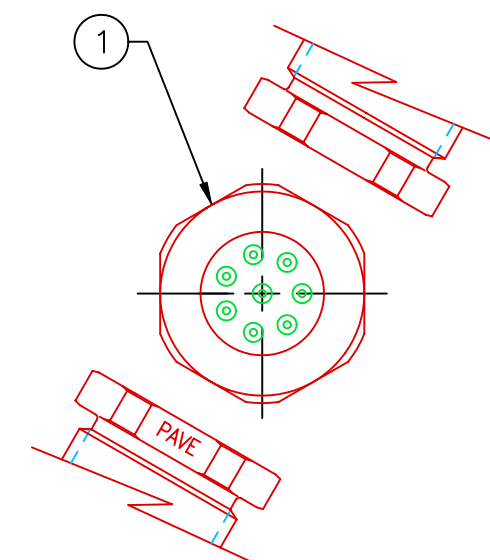

NOTES:

1. OPERATING RANGE: -40°C TO 90°C.
2. ELECTRICAL TEST: HYPOT 630 VDC 500 MΩ 0.01 SEC MINIMUM WIRE TO WIRE.
3. LEAK TEST: 80 PSI N2, NO BUBBLES 1 MINUTE MINIMUM.
4. QUALIFICATION LEAK TEST: 40 PSI N2, BIDIRECTIONAL NO BUBBLES 1 MINUTE MINIMUM.
5. WIRE-.5mm², 16/19 STRANDED TINNED COPPER W/ 105°C PVC HARMONIZED TO HO5V2-K.
6. STRIP & RETAIN ALL WIRE ENDS: HEX SIDE STRIP .12-.16 [3-4mm] & THREAD SIDE .23-.28 [6-7mm]. IT IS ACCEPTABLE FOR RETAINED ENDS TO BE LOST DURING HANDLING.
7. LEAK TESTING DONE WITH -117 O-RING W/NO LUBE, REMOVED AFTER TESTING.
8. PARTING LINE ON HOUSING IS ACCEPTABLE PROVIDING MATERIAL IS ADDED +.010 [2.5], FOR TOTAL MISMATCH IN THREADS ACROSS PARTING LINE TOLERANCE GRADE IS 8g.
10. DIMENSIONS ARE INCHES [millimeters].

WIRE#	COLOR	X	Y
1	BROWN	4.33+.40/-.10 [110+10.0/-2.5]	4.53+.40/-.10 [115+10.0/-2.5]
2	ORANGE	4.33+.40/-.10 [110+10.0/-2.5]	4.53+.40/-.10 [115+10.0/-2.5]
3	YELLOW	8.27+.40/-.10 [210+10.0/-2.5]	4.53+.40/-.10 [115+10.0/-2.5]
4	GREEN	8.27+.40/-.10 [210+10.0/-2.5]	4.53+.40/-.10 [115+10.0/-2.5]
5	BLUE	3.54+.40/-.10 [90+10.0/-2.5]	4.53+.40/-.10 [115+10.0/-2.5]
6	VIOLET	3.54+.40/-.10 [90+10.0/-2.5]	4.53+.40/-.10 [115+10.0/-2.5]
7	RED	2.36+.40/-.10 [60+10.0/-2.5]	5.51+.40/-.10 [140+10.0/-2.5]
8	BLACK	2.36+.40/-.10 [60+10.0/-2.5]	5.51+.40/-.10 [140+10.0/-2.5]

3	12	HAR20 *****	WIRE, NOTE5 & *****=COLOR (ø2.15mm MAX)
2	A/R	PAVE-Seal 150	EPOXY BLACK
1	1	1201	HOUSING M24x1.5-V
ITEM	QTY	PART#	DESCRIPTION

ALL DIMENSIONS AND TOLERANCES APPLY TO FINISHED PART IN INCHES
 ALLOWABLE TOLERANCES UNLESS SPECIFIED OTHERWISE: NONE +/-0.5
 .X DECIMAL +/- 0.1 .XX DECIMAL +/- 0.02 .XXX DECIMAL +/-0.005
 ANGLES +/- 1 DEG SURFACE FINISH 128 microinch RMS

2751 Thunderhawk Court
 Dayton, Ohio 45414-3445
 U.S.A.
 (937)890-1100
 fax (937)890-5165
 www.pavetechnologyco.com

PAVE technology co.

DESCRIPTION PAVE-Seal Cable Harnesses
M24-V-150-8-HAR20-6-5

PART NUMBER **1204**

REVISION LEVEL **D**

PROJECTION