

SPF12 INSTALLATION PORT

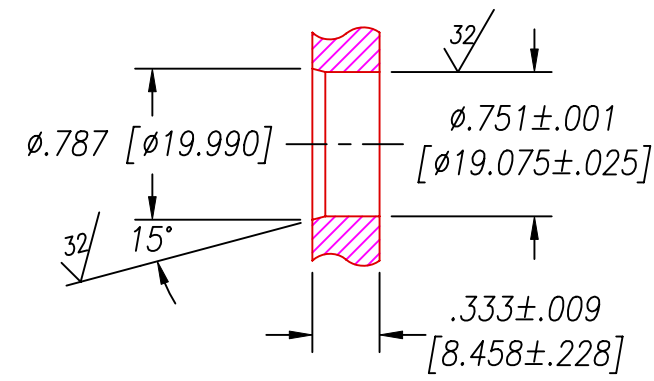

RECOMMENDED RETAINING RING
TRUARC #5100-75 OR EQUAL

NOTES:

1. LEAK TEST: 80 PSI, NO BUBBLES 2 MINUTES MINIMUM.
2. HYPOT 630 VDC 500 MΩ 0.01 SEC MINIMUM, WIRE TO WIRE.
3. ALL TESTS ARE PERFORMED AT ROOM TEMPERATURE.
4. ALL PARTS MUST PASS ALL TESTS.
5. WIRES ARE NOT REQUIRED TO BEND SHARPLY AT EPOXY SEAL SURFACE.
6. NO VOIDS ARE ACCEPTABLE ON O-RING SEALING SURFACES, VOIDS SMALLER THAN $\phi.035$ [0.89] ARE ACCEPTABLE ON ALL OTHER SURFACES.
7. DIMENSIONS ARE INCHES [millimeters].

6	A/R	PARKER O-LUBE	LUBRICANT O-RING BARIUM-BASED
5	1	-016 VITON	O-RING -016 VITON 75
4	1	E24 WHITE	WIRE 24E MIL-W-16878/4 7/#32
3	1	F01B090-ASP	WIRE HIGH VOLTAGE 22 AWG
2	A/R	PAVE-Seal 150	EPOXY BLACK
1	1	0130	HOUSING SPF12-E
ITEM	QTY	PART#	DESCRIPTION

ALL DIMENSIONS AND TOLERANCES APPLY TO FINISHED PART IN INCHES
ALLOWABLE TOLERANCES UNLESS SPECIFIED OTHERWISE: NONE +/-0.5
.X DECIMAL +/- 0.1 .XX DECIMAL +/- 0.02 .XXX DECIMAL +/-0.005
ANGLES +/- 1 DEG SURFACE FINISH 128 microinch RMS

 2751 Thunderhawk Court
 Dayton, Ohio 45414-3445
 U.S.A.
 (937)890-1100
 fax (937)890-5165
 www.pavetechnologyco.com

DESCRIPTION **PAVE-Seal Cable Harnesses**
SPF12-E-150-1/1-TE24/F01B090-24-24

PART NUMBER **1659**

REVISION LEVEL **A**

PROJECTION 