

RECOMMENDED PANEL CUTOUT REF ONLY

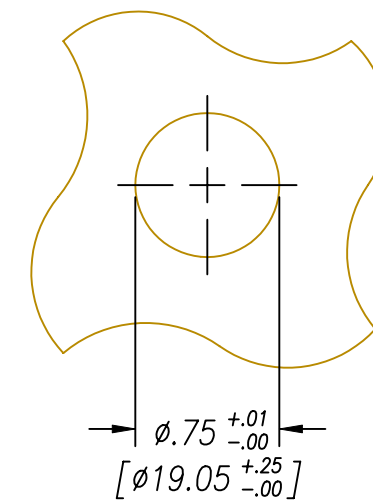

NOTES:

- 1a. 1861: LEAK TEST @ 1500 PSI, 30 SEC, NO BUBBLES.
- 1b. 1861-1: LEAK TEST @ 80 PSI, 30 SEC, NO BUBBLES.
- 2. HYPOT 630 VDC 500 MEGOHMS .01 SEC MINIMUM, CONTACT TO SHIELD & HOUSING.
- 3. ALL HOUSING DIMENSIONS FOR REFERENCE ONLY.

6	1	31-2221	RCPT BNC UG-1094A 50 OHM
5	A/R	PAVE-Seal 150	EPOXY BLACK
4	2	AMP #66569-3	CONTACT SOLDER CUP #20
3	1	-116 VITON	O-RING -116 VITON 75
2	1	8L5N-SS	NUT VS12-SS
1	1	1180	HOUSING VS12L-SS
ITEM	QTY	PART #	DESCRIPTION

ALL DIMENSIONS AND TOLERANCES APPLY TO FINISHED PART IN INCHES
 ALLOWABLE TOLERANCES UNLESS SPECIFIED OTHERWISE: NONE +/-0.5
 .X DECIMAL +/- 0.1 .XX DECIMAL +/- 0.02 .XXX DECIMAL +/-0.005
 ANGLES +/- 1 DEG SURFACE FINISH 128 microinch RMS

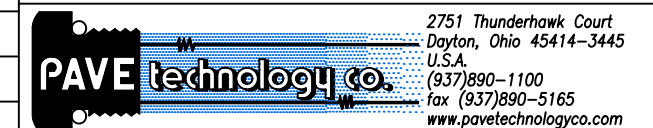

DESCRIPTION PAVE-Mate II Connectors
 VS12L-SS-150-1-BNC-SC

PART NUMBER 1861 SEE NOTES

REVISION LEVEL A

PROJECTION