

O-RING GROOVE DETAIL  
SCALE 4=1

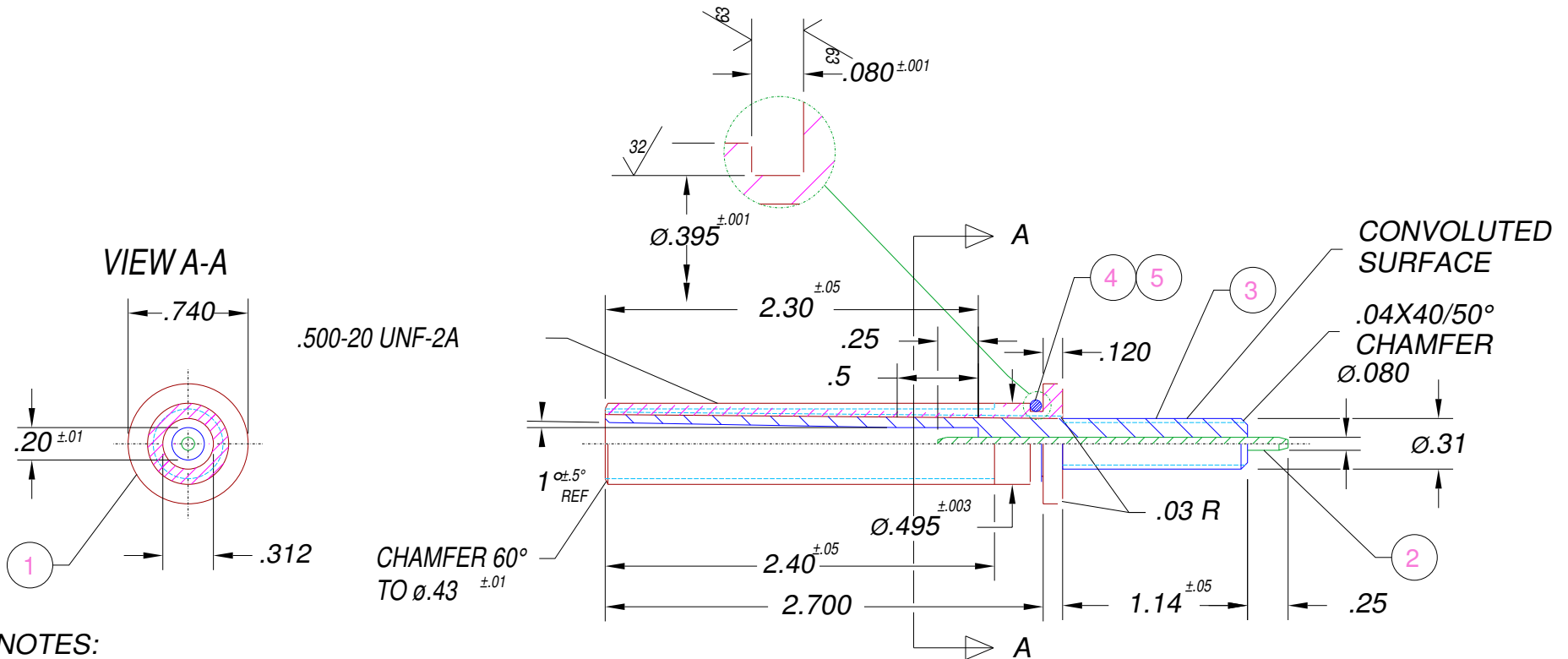

NOTES:

1. HE LEAK TEST @1 ATM.  $<10^{-7}$  CC/S.
2. HYPOT 25000 VDC (MAX LEAKAGE TBD) CONDUCTOR TO HOUSING.
3. ALL TESTS ARE PERFORMED AT ROOM TEMPERATURE.
4. ALL SPECIFICATIONS AND TESTS SUPERSEDE PAVE CATALOG SPECIFICATIONS.

5	A/R	SUPER O-LUBE	LUBRICANT O-RING SILICONE BASED
4	1	-012 VITON	O-RING -012 VITON 75
3	A/R	PAVE-Seal 80HV	EPOXY BLUE
2	1	BARE COPPER #12	WIRE 12 BARE COPPER SOLID
1	1	2077	HOUSING VS8XL-AL (ELECTROLESS NICKEL PLATED)
ITEM	QTY	PART#	DESCRIPTION

ALL DIMENSIONS AND TOLERANCES APPLY TO FINISHED PART IN INCHES  
 ALLOWABLE TOLERANCES UNLESS SPECIFIED OTHERWISE: NONE +/- .5  
 .X DECIMAL +/- .1 .XX DECIMAL +/- .02 .XXX DECIMAL +/- .005  
 ANGLES +/- 1 DEG SURFACE FINISH 128 microinch RMS



DESCRIPTION *PAVE-Seal® Cable Harnesses*  
**VS8XL-AL-80HV-1-.08CU-1.3-.5**

PART NUMBER

**2053**

PROJECTION

