

BULKHEAD DIMENSIONS

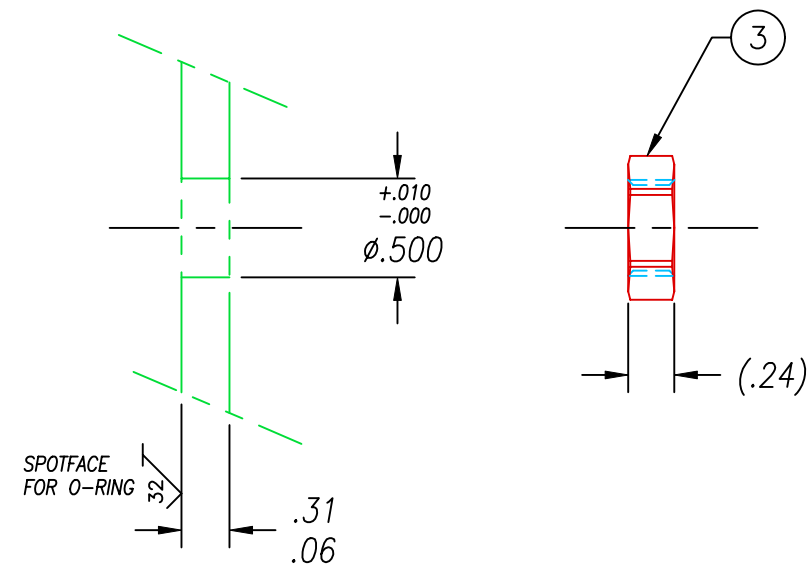

NOTES:

1. HE LEAK TEST @1 ATM. 10^{-7} CC/S
2. LEAK TEST: 50 BAR (725 PSI) THREAD SIDE, 2 MINUTES MINIMUM, NO VISIBLE LEAKS, QUALIFICATION ONLY.
3. OPTICAL CONTINUITY: 2.0 dB ATTENUATION @ 850nm SOURCE TO METER.
4. ALL TESTS ARE DONE AT ROOM TEMPERATURE.
5. SHIP ASSEMBLY WITH ADAPTORS CAPPED TO PROTECT AGAINST DAMAGE/CONTAMINATION.

8	A/R	SUPER O-LUBE	LUBRICANT O-RING SILICONE-BASED
7	1	THOR#BFL37-1000	FIBER MULTIMODE 0.37 NA LOW OH 1000 CORE
6	2	THOR#11275A	FERRULE 1250u SMA STEEL (COMPONENT)
5	1	0892	HOUSING VS8-SS
4	1	-112 VITON	O-RING -112 VITON 75A
3	1	0894	NUT VS8-SS
2	A/R	PAVE-Seal 150	EPOXY BLACK
1	2	THOR#ADASMA	ADAPTOR SMA STYLE SS
ITEM	QTY	PART#	DESCRIPTION

ALL DIMENSIONS AND TOLERANCES APPLY TO FINISHED PART IN INCHES
 ALLOWABLE TOLERANCES UNLESS SPECIFIED OTHERWISE: NONE +/-0.5
 .X DECIMAL +/- 0.1 .XX DECIMAL +/- 0.02 .XXX DECIMAL +/-0.005
 ANGLES +/- 1 DEG SURFACE FINISH 128 microinch RMS



DESCRIPTION PAVE-Opti Seal™ Cable Harnesses
 VS8-SS-150-1-1000u(Low OH)-SMA-SMA

PART NUMBER
 3126

REVISION LEVEL B
 PROJECTION