

7	E26 ORANGE	14	E26 RED	21	E26 BLACK 7STRD		
6	E26 WHITE	13	E26 YELLOW	20	E26 BROWN 7STRD		
5	E26 GRAY	12	E26 BLUE	19	E26 YELLOW		
4	E26 PURPLE	11	E26 GRAY	18	E26 BROWN 7STRD	25	E26 GREEN
3	E26 BLACK 7STRD	10	E26 PURPLE	17	E26 BLUE	24	E26 BLUE
2	E26 WHITE	9	E26 WHITE	16	E26 BLACK 7STRD	23	E26 GRAY
1	E26 RED	8	E26 PURPLE	15	E26 ORANGE	22	E26 ORANGE
PIN	PART#	PIN	PART#	PIN	PART#	PIN	PART#

16	1	AMP #745187-1	CONN DSUB 25S FEMALE -OR EQUIVALENT-
15	2	E26 YELLOW	WIRE 26E MIL-W-16878/4 7/#34
14	2	E26 BROWN 7STRD	WIRE 26E MIL-W-16878/4 7/#34
13	3	E26 ORANGE	WIRE 26E MIL-W-16878/4 7/#34
12	1	E26 GREEN	WIRE 26E MIL-W-16878/4 7/#34
11	3	E26 BLUE	WIRE 26E MIL-W-16878/4 7/#34
10	3	E26 GRAY	WIRE 26E MIL-W-16878/4 7/#34
9	3	E26 PURPLE	WIRE 26E MIL-W-16878/4 7/#34
8	3	E26 WHITE	WIRE 26E MIL-W-16878/4 7/#34
7	3	E26 BLACK 7STRD	WIRE 26E MIL-W-16878/4 7/#34
6	2	E26 RED	WIRE 26E MIL-W-16878/4 7/#34
5	2	JACKPOST 4-40	"P" STYLE 4-40 UNC
4	1	-026 VITON	O-RING -026 VITON 75
3	A/R	PAVE-Seal 150	EPOXY BLACK
2	1	3526	PLATE TOP SS D-SUB 25
1	1	4007-25	PLUG D-SUB 25 PIN
ITEM	QTY	PART NUMBER	DESCRIPTION

- NOTES:
- HE LEAK TEST VACUUM 10X10<sup>-7</sup> CC/SEC OR LESS.
  - HYPOT 630 VDC 500 MEGOHMS MINIMUM 0.01 SECOND MINIMUM WIRE TO WIRE AND HOUSING.
  - CONTINUITY TEST PER TABLE <60 MILLIOhms MATING CONNECTOR TO WIRE END.
  - ALL TESTS ARE PERFORMED AT ROOM TEMPERATURE.
  - ALL PARTS MUST PASS ALL TESTS.
  - WIRE POSITIONING IS APPROXIMATE & VARIABLE.
  - NO VOIDS ARE ACCEPTABLE ON O-RING SEALING SURFACES, VOIDS SMALLER THAN Ø0.035 ARE ACCEPTABLE ON ALL OTHER SURFACES.
  - DIMENSION IS OVER-ALL-LENGTH EXCLUDING OVERFILL ON PRESSURE SIDE OF HOUSING.
  - REF-OPERATING TEMPERATURE -30 °C TO 125 °C.
  - DIMENSIONS ARE INCHES[MILLIMETERS]
  - ITEM 16 (NOT SHOWN), TO BE SHIPPED WITH PART.

ALL DIMENSIONS AND TOLERANCES APPLY TO FINISHED PART IN INCHES.  
 ALLOWABLE TOLERANCES UNLESS SPECIFIED OTHERWISE: NONE ±0.5  
 X.X DECIMAL ±0.1 X.XX DECIMAL ±0.02 X.XXX DECIMAL ±0.005  
 ANGLES ±1 DEGREE SURFACE FINISH 128 microinch RMS

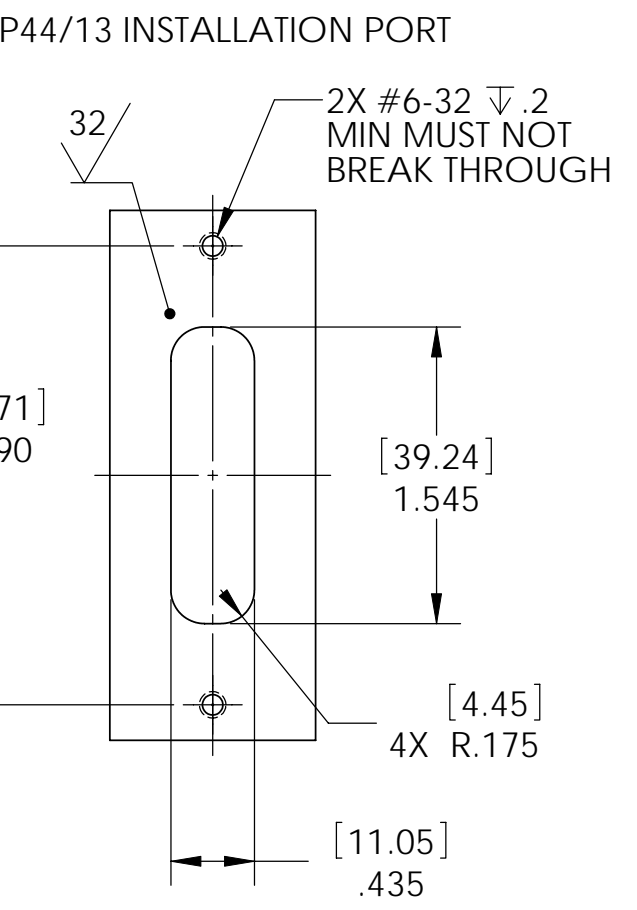

**PAVE technology co.**  
 2751 Thunderhawk Court  
 Dayton, OH 45414-3445  
 U.S.A.  
 tel (937) 890-1100  
 fax (937) 8905165  
 www.pavetechnologyco.com

DESCRIPTION  
 SP44/13-E-150-25-TE26-DSUB25-24

PART NUMBER  
**3871**

MATERIAL NOTED

REVISION LEVEL -

PROJECTION