

SEE NOTES 13 & 14

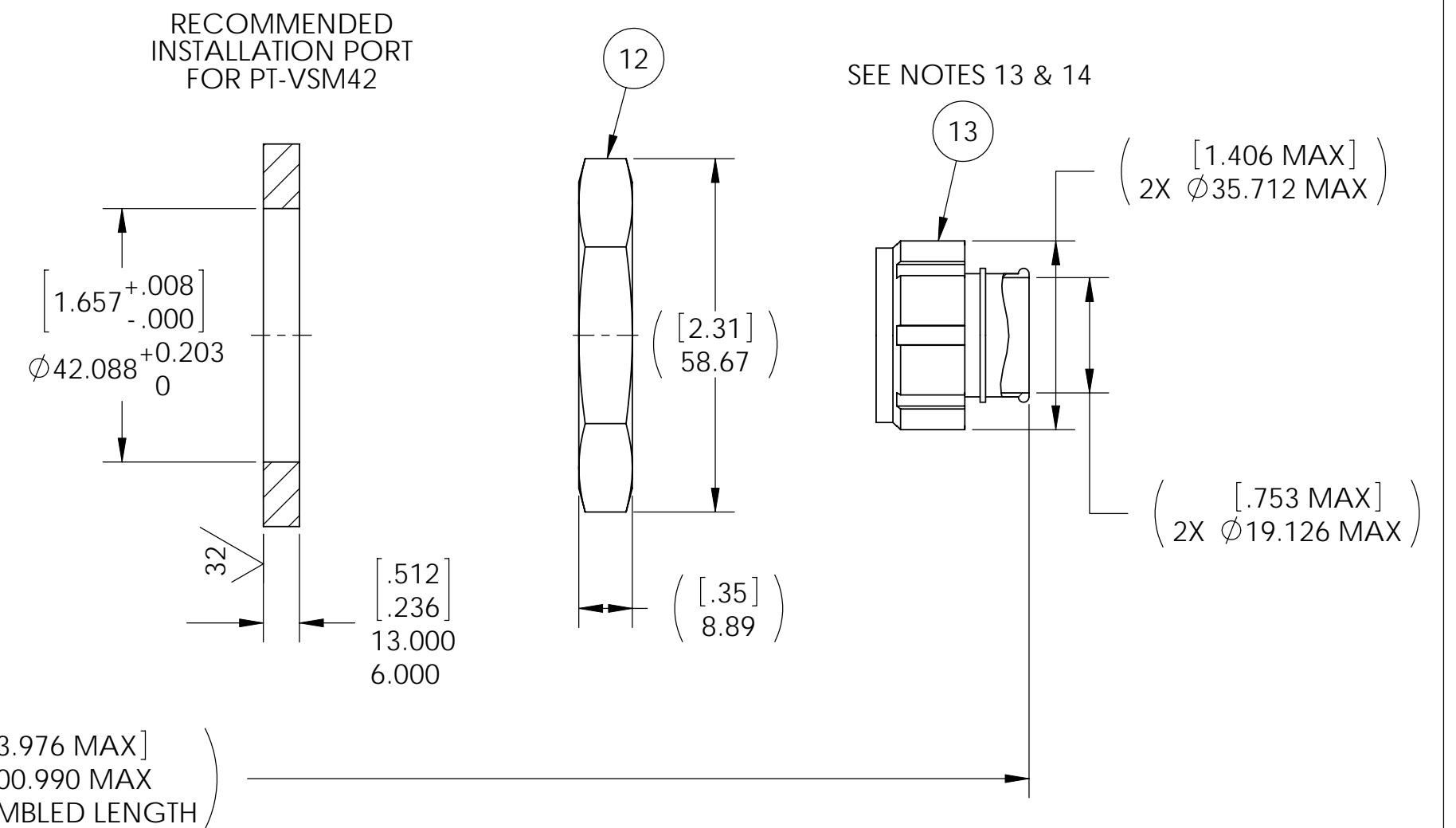
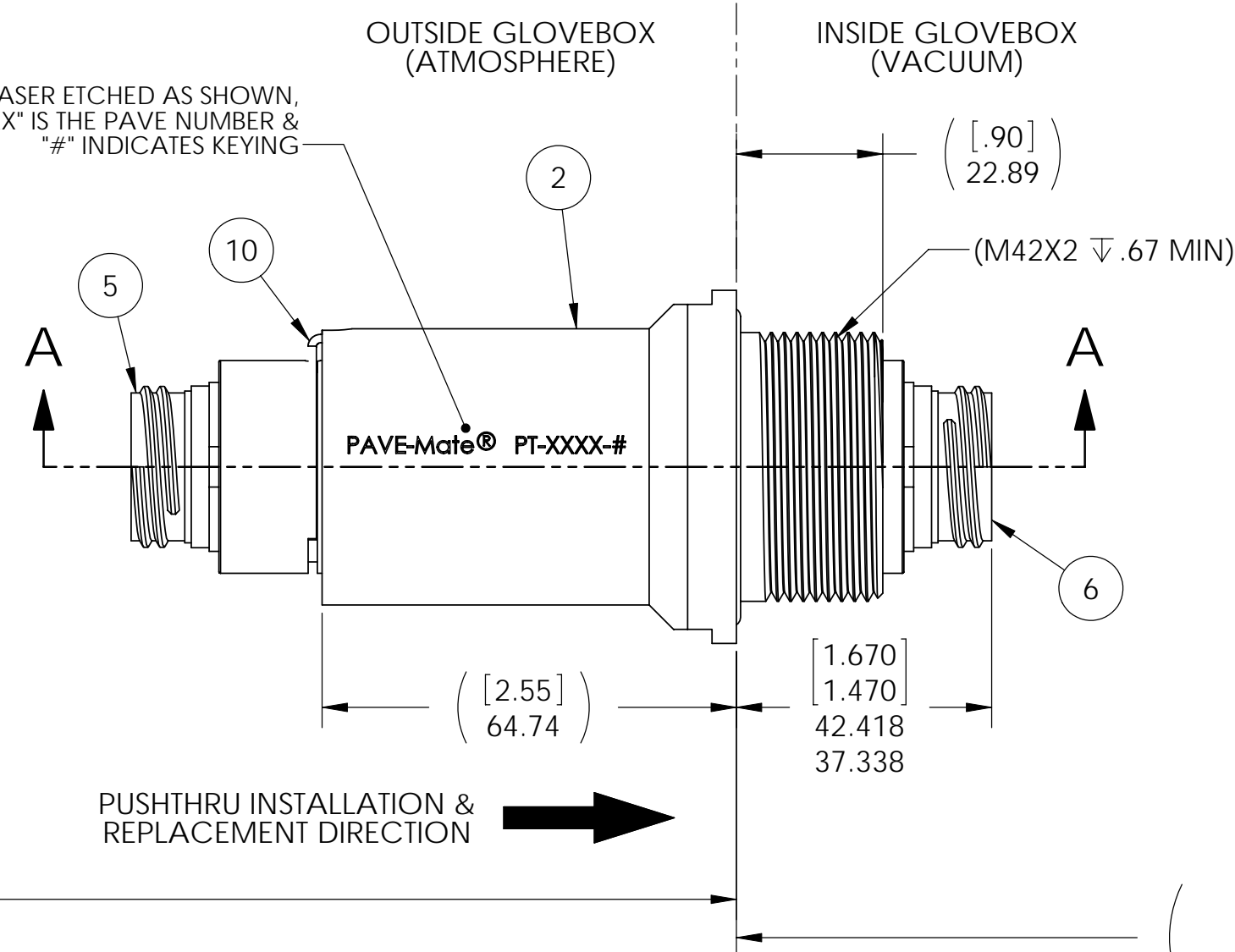
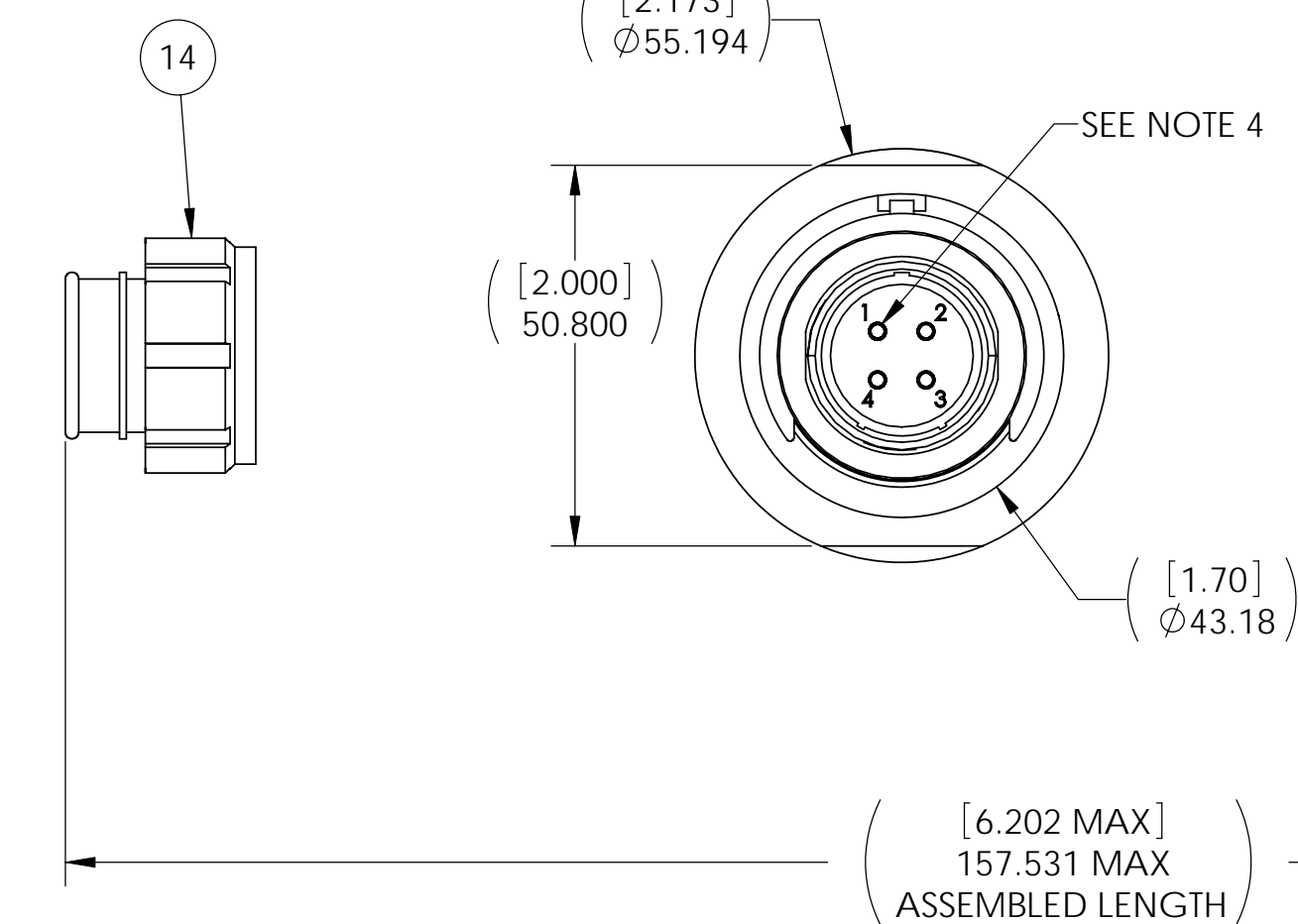

CONNECTOR TOOLING INFORMATION

PART NUMBER	TOOL FUNCTION/DESCRIPTION
M22520/1-01	HAND CRIMP TOOL MIL-SPEC
M22520/1-04	CRIMP POSITIONER FOR M22520/1-01
ATML 0809B	INSERTION TOOL #12 CONTACT
ATML 0810B	REMOVAL TOOL #12 CONTACT
600-061	BANDING INSTALLATION TOOL

NOTES:

- HE LEAK TEST @1 ATMOSPHERE PRESSURE, 10X10⁻⁶ CC/SEC OR LESS.
- PRODUCTION HYPOT TEST: 630 VDC 500 MEGOHMS MINIMUM 0.01 SECOND MINIMUM PIN TO PIN AND HOUSING WITH MATING CONNECTORS.
- QUALIFICATION TEST ONLY:
A.) GROUNDING IMPEDANCE TEST PER UL 1977 SECTION 21.
B.) DIELECTRIC VOLTAGE-WITHSTAND TEST PER UL 1977 SECTION 17.
- CONTINUITY TEST: <0.1 OHM PIN TO SOCKET WITH MATING CONNECTORS.
- SUGGESTED OPERATING VOLTAGE: 600 VAC.
- CURRENT RATING: 13 AMPS.
- THE FIRST POSITION PIN CONTACT ("GROUND CONNECTOR PIN") IN ITEM 5 & ITEM 13 WILL BE SLIGHTLY LONGER FOR FIRST MATE/LAST BREAK ("FMLB"). TO ORDER SPARE "FMLB" CONTACTS USE PAVE PART NUMBER: 4235-1-12P.
- ALL TESTS ARE PERFORMED AT ROOM TEMPERATURE (15°C TO 40°C).
- ALL PARTS MUST PASS ALL TESTS.
- NO VOIDS ARE ACCEPTABLE ON O-RING SEALING SURFACES, VOIDS SMALLER THAN Ø0.89 [0.035] ARE ACCEPTABLE ON ALL OTHER SURFACES.
- REF-OPERATING TEMPERATURE RANGE -20°C TO 125°C.
- THE "#" IN THE PAVE PART NUMBER, COMPONENT PART NUMBERS & ASSOCIATED DESCRIPTIONS IS FOR KEYING IDENTIFICATION. KEYS ARE FROM "1" THROUGH "6".
- STAINLESS STEEL SHIELDING TERMINATION BANDS FOR ITEMS 13 & 14 ARE INCLUDED BUT NOT SHOWN.
- TO ORDER SPARE PENETRATORS ADD "NP" TO THE PAVE PART NUMBER. THIS INDICATES ITEMS 13 & 14 (PLUGS) ARE NOT INCLUDED, ALL OTHER ITEMS LISTED IN THE BILL OF MATERIALS WILL BE INCLUDED. PART EXAMPLE: PAVE#: PT-4109-3NP
- REF-REMOVEABLE MOLDED EPOXY CORES ARE DEFLASHED ON PARTING LINE +0.13 [0.005] MAXIMUM.
- REF-STORE ASSEMBLIES IN A CLEAN, DRY PLACE IN SEALED POLY BAG AS SUPPLIED WITH PLASTIC PROTECTIVE CAPS BETWEEN -20°C AND 60°C. PARTS ARE PACKAGED PER NQA-1 1994, LEVEL B.
- DIMENSIONS ARE MILLIMETERS [INCHES].

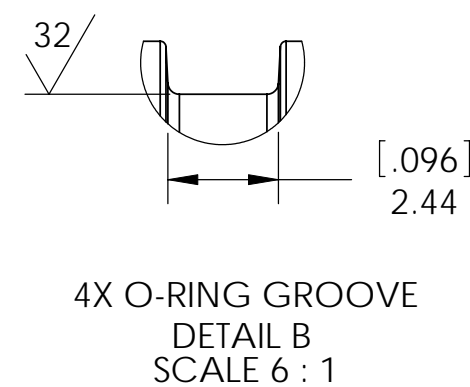
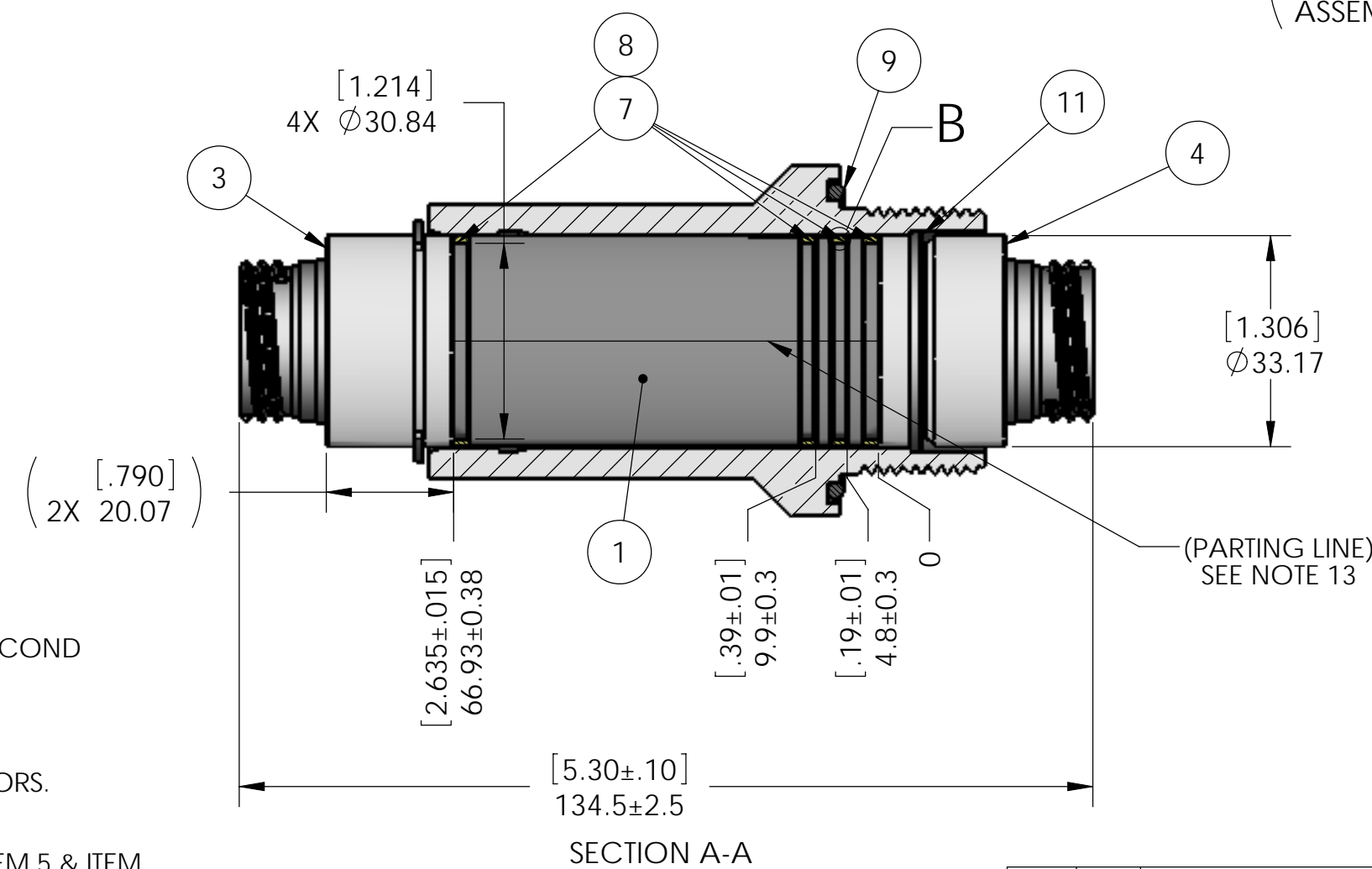

SPARE CONTACT, BANDING, & PROTECTIVE CAP ORDERING INFORMATION

QTY	PART NUMBER	DESCRIPTION
1	4235-1-12P	PIN #12 FMLB (Au OVER Ni PLATED BeCu) SEE NOTE 7
3	4235-2-12P	PIN #12 (Au OVER Ni PLATED BeCu)
4	4235-1-12S	SOC #12 (Au OVER Ni PLATED BeCu W/SS HOOD)
2	4109SR	BAND 300 SERIES SS 8.125" X .120" PRE-COILED
2	3951	RCPT CAP W/ WIRE ROPE LANYARD & ATTACHMENT RING SS

ITEM	QTY	PART NUMBER	DESCRIPTION
1	A/R	PAVE-Seal 150	MOLDED REPLACEABLE HERMETIC EPOXY PUSHTHRU CORE BLACK
2	1	4070	HOUSING VSM42-SS (304SS)
3	1	4289	ADAPTER ARRR NYLATRON C4 15/16-20
4	1	4288	ADAPTER AWSR NYLATRON C4 15/16-20
5	1	PT-4109-R-PN-#	RCPT (304SS SHELL/GLCP-30F/FLUOROSILICONE) 4#12 PIN (Au OVER Ni PLATED BeCu) MM KEYED#
6	1	PT-4109-R-SN-#	RCPT (304SS SHELL/GLCP-30F/FLUOROSILICONE) 4#12 SOC (Au OVER Ni PLATED BeCu W/SS HOOD) MM KEYED#
7	4	-025 VITON 60	O-RING -025 VITON 60+/-5 DUROMETER
8	A/R	DC 710	LUBRICANT O-RING DOW CORNING 710 FLUID
9	1	-132 VITON 60	O-RING -132 VITON 60+/-5 DUROMETER
10	1	4076	ANTI-ROTATION RETAINING RING SIZE 4 (304SS)
11	1	4077	ANTI-WITHDRAW SPRING RING SIZE 4 (304SS)
12	1	4073	NUT M42X2-SS (316LSS)
13	1	4109-#P SEE NOTE 14	PLUG W/ BANDED BACKSHELL (304SS SHELL/GLCP-30F/FLUOROSILICONE) 4#12 PIN (Au OVER Ni PLATED BeCu) MM KEYED#, 300 SERIES SS BAND INCLUDED
14	1	4109-#S SEE NOTE 14	PLUG W/ BANDED BACKSHELL (304SS SHELL/GLCP-30F/FLUOROSILICONE) 4#12 SOC (Au OVER Ni PLATED BeCu W/SS HOOD) MM KEYED#, 300 SERIES SS BAND INCLUDED

PAVE technology co.
 2751 Thunderhawk Court
 Dayton, OH 45414-3445
 U.S.A.
 tel (937) 890-1100
 fax (937) 8905165
 www.pavetechnologyco.com

DESCRIPTION PAVE-Mate® I Connectors
 PT-VSM42-SS-150-4-12-MMTC16PS#
 MATERIAL NOTED

PART NUMBER PT-4109-#
 REVISION LEVEL 4
 PROJECTION

FINISH ALL DIMENSIONS AND TOLERANCES APPLY TO FINISHED PART IN MILLIMETERS.
 ALLOWABLE TOLERANCES UNLESS SPECIFIED OTHERWISE: NONE ±12.700,
 .XX DECIMAL ±2.540, .XXX DECIMAL ±0.508, .XXXX DECIMAL ±0.127,
 ANGLES ±1 DEGREE, SURFACE FINISH 128 microinch RMS