

EPOXY UNDERFILL .08 [2.0] MAXIMUM,
NO OVERFILL ALLOWED EXCLUDING
MENISCUS ON CABLE, BOTH SIDES

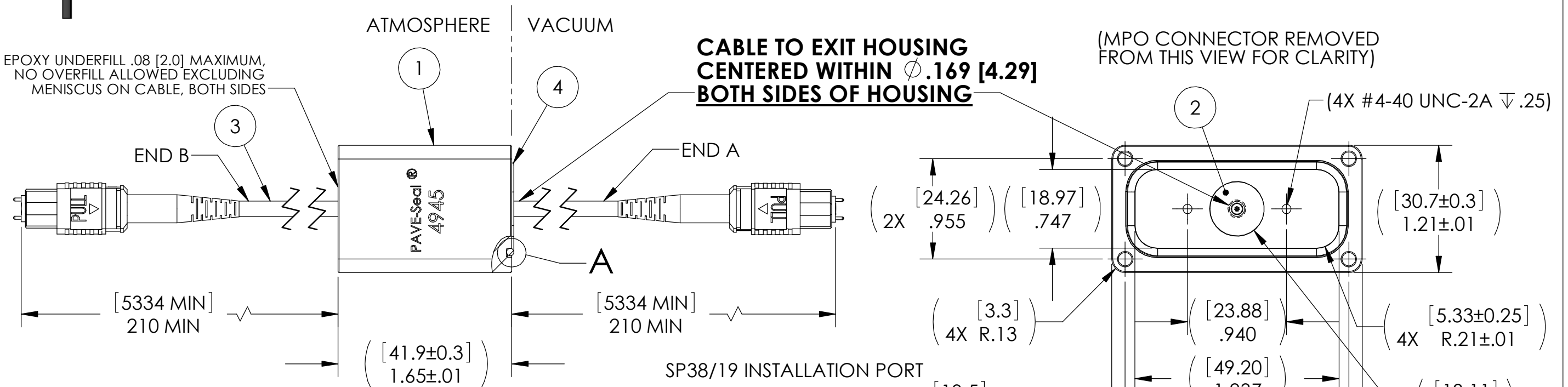

NOTES:

1. HE LEAK TEST @ 1 ATM. 1×10^{-8} CC/SEC OR LESS. A GREEN PAINT DOT INDICATES THE PART HAS PASSED THE TEST.
2. OPTICAL CONTINUITY CHECK BROWN (#4) AND YELLOW (#9) FIBERS WITH LASER, ALL OTHER FIBERS MUST BE PRESENT IN JACKET BUT CONTINUITY IS NOT REQUIRED.
3. REF-MPO CONNECTORS HAVE "CROSSED/REVERSE" POLARITY.
4. ALCOHOL OR FOMBLIN YVAC 3 MAY BE USED TO LUBRICATE O-RINGS FOR VACUUM HELIUM LEAK TESTING.
5. ALL TESTS ARE PERFORMED AT ROOM TEMPERATURE.
6. ALL PARTS MUST PASS ALL TESTS.
7. COSMETIC SURFACE VOIDS SMALLER THAN $\phi 0.035$ [0.89] ARE ACCEPTABLE.
8. REF-OPERATING TEMPERATURE RANGE -35°C TO 95°C.
9. CABLE OUTER JACKET AND KEVLAR FIBERS TO WITHSTAND 10LB PULL TEST ON BOTH SIDES OF FEEDTHRU WITHOUT COMING LOOSE.
10. DIMENSIONS ARE INCHES [millimeters].

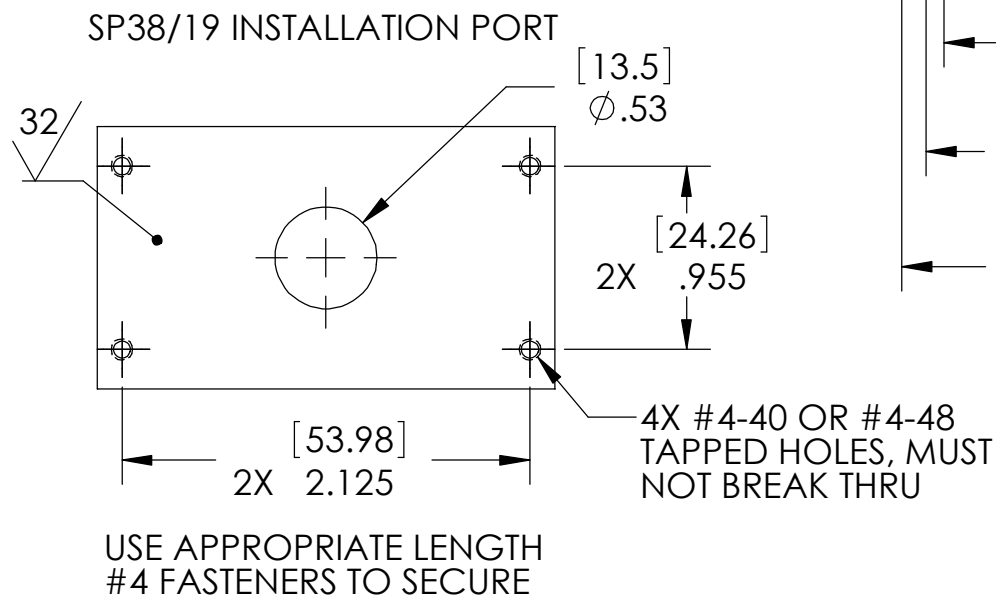

ITEM	QTY	PART NUMBER	DESCRIPTION
4	1	-030 V1289-75	O-RING -030 VITON LOW TEMP V1289-75
3	1	V5070	CABLE ASSEMBLY MMFO 12 FIBERS 250um ACRYLATE BUFFERD 50/125um + KEVLAR + JACKET + MPO CONNECTORS (439" MIN OAL)
2	A/R	PAVE-Seal 150	EPOXY BLACK
1	1	4946	HOUSING SP38/19-SS

PAVE technology co.

2751 Thunderhawk Court
Dayton, OH 45414-3445
U.S.A.
tel (937) 890-1100
fax (937) 8905165
www.pavetechnologyco.com

DESCRIPTION
SP38/19-SS-150-2-MMFO-210-210

PART NUMBER
4945

MATERIAL NOTED

REVISION LEVEL
C

PROJECTION

ALL DIMENSIONS AND TOLERANCES APPLY TO FINISHED PART IN INCHES.
ALLOWABLE TOLERANCES UNLESS SPECIFIED OTHERWISE: NONE ±0.5
X.X DECIMAL ±0.1 X.XX DECIMAL ±0.02 X.XXX DECIMAL ±0.005
ANGLES ±1 DEGREE SURFACE FINISH 128 microinch RMS