

WIRE PIN-OUT TABLE				
ITEM#	POSITION	WIRE COLOR	ITEM#	POSITION
2	A	RED	8	A
2	B	ORANGE	12	N/A
2	C	BLUE	6	1
2	D	BLACK	8	D
2	E	BROWN	10	N/A
2	F	VIOLET	6	2

REF-CONNECTOR POSITIONS, VIEWED FROM MATING SURFACE

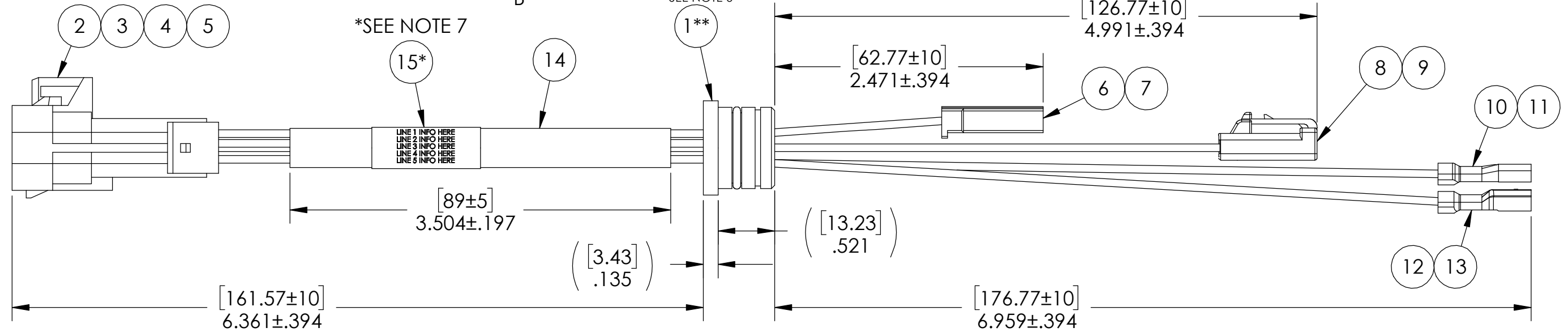
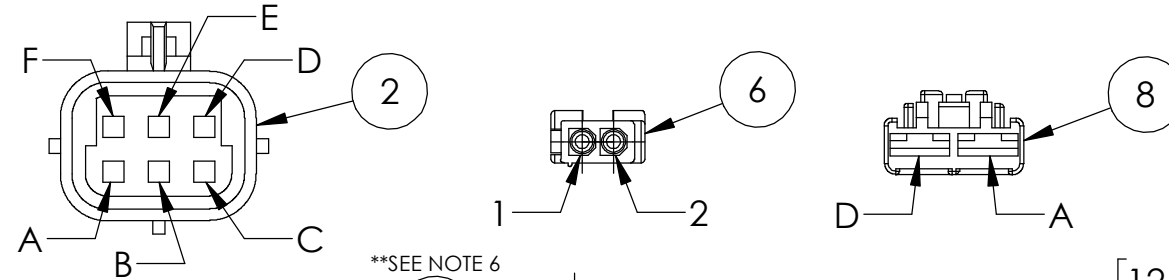

NOTES:

1. HYPOT 630 VDC 500 MEGOHMS MINIMUM 0.01 SECOND MINIMUM WIRE TO WIRE WITH MATING CONNECTORS.
2. ALL CIRCUITS MUST HAVE CONTINUITY.
3. SHORT, OPEN, OR CROSSED CIRCUITS ARE NOT PERMISSIBLE.
4. ALL TESTS ARE PERFORMED AT ROOM TEMPERATURE.
5. ALL PARTS MUST PASS ALL TESTS.
6. REFERENCE PAVE DRAWING# 5045 FOR COMPLETE SUB-ASSEMBLY DETAILS.
7. APPLY IDENTIFICATION LABEL APPROXIMATELY WHERE SHOWN, INFORMATION PRINTED ON LABEL AS FOLLOWS:  
 LINE 1 = "PAVE TECHNOLOGY CO."  
 LINE 2 = "5025 REV A"  
 LINE 3 = MFG DATE: MM/DD/YY R (R = PAVE REV LEVEL)  
 LINE 4 = "DAYTON OHIO U.S.A."
8. PARTS SHALL BE PACKAGED TO PREVENT DUST, DIRT, CARDBOARD, GREASE, ETC. FROM CONTAMINATING THE WIRING HARNESS.
9. DIMENSIONS ARE INCHES [millimeters].
10. REF-5045-1 LEAK TEST: 80 PSI, NO BUBBLES 1 MINUTE MINIMUM. A GREEN PAINT DOT INDICATES THE PART HAS PASSED THE TEST.
11. COSMETIC SURFACE VOIDS NOT ON O-RING SEALING SURFACES ARE ACCEPTABLE BASED ON THE SEAL'S DIAMETER:  
 <= .5 [12.7] SEAL DIAMETER:  $\phi$ .035 [.89] MAX ALLOWED VOID SIZE  
 > .5 [12.7] SEAL DIAMETER:  $\phi$ 0.060 [1.5] MAX ALLOWED VOID SIZE
12. REF-5045 OPERATING TEMPERATURE RANGE -20 °C TO 125 °C.

15	1	THT-10-427-3	LABEL SELF-LAMINATING WHITE VINYL 1 INCH LONG
14	1	602-PVC105-0-100BK	TUBING NON-SHRINKABLE PVC ASTM D922, GRADE C BLACK .325 ID X .020 WALL
13	1	174817-1	INSULATION SLEEVE TE CONNECTIVITY 250 SERIES POSITIVE LOCK-EX PVC BLUE
12	1	175022-1	TERMINAL FEMALE TE CONNECTIVITY 250 SERIES POSITIVE LOCK-EX TIN PLATED BRASS
11	1	174737-2	INSULATION SLEEVE TE CONNECTIVITY 187 SERIES POSITIVE LOCK-EX PVC YELLOW
10	1	173724-1	TERMINAL FEMALE TE CONNECTIVITY 187 SERIES POSITIVE LOCK-EX TIN PLATED BRASS
9	2	42100-2	TERMINAL FEMALE TE CONNECTIVITY 250 SERIES FASTIN-FASTON TIN PLATED BRASS
8	1	346027-1	RECEPTACLE HOUSING TE CONNECTIVITY 2 WAY FASTIN-FASTON
7	2	171637-1	CONTACT SOCKET TE CONNECTIVITY MINI MATE-N-LOCK 20-16AWG TIN PLATED BRASS
6	1	172233-1	CONNECTOR TE CONNECTIVITY 2 POS MINI MATE-N-LOCK
5	1	12052850	LOCK SECONDARY TPA DELPHI 6 WAY MEDIUM GRAY METRI-PACK 150
4	6	15324973	CABLE SEAL 1 WAY DELPHI METRI-PACK INDIVIDUAL ROUND RED SILICONE
3	6	12045773	TANG TERMINAL MALE SEALED DELPHI METRI-PACK 150 TIN PLATED COPPER ALLOY
2	1	12124107	CONNECTOR DELPHI 6 WAY BLACK METRI-PACK 150 SEALED MALE 14 AMPS MAX
1	1	5045-1	SPF12-E-150-6-TZ18-7-8

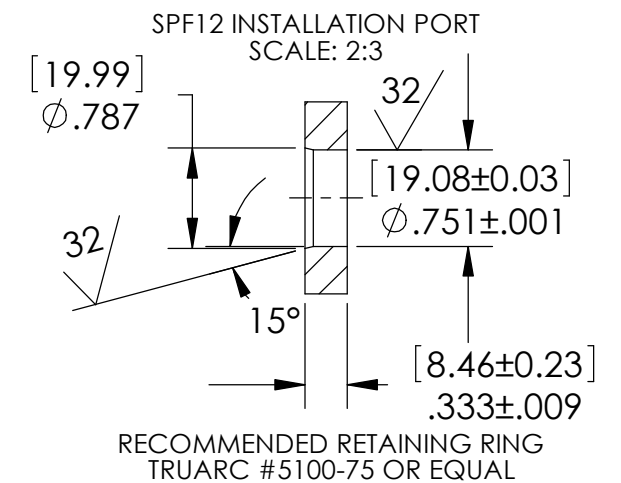

**PAVE technology co.**  
 2751 Thunderhawk Court  
 Dayton, OH 45414-3445  
 U.S.A.  
 tel (937) 890-1100  
 fax (937) 8905165  
 www.pavetechnologyco.com

DESCRIPTION		SPF12-E-150-6-TZ18-6.4T-7T	
PART NUMBER	MATERIAL	NOTED	
<b>5025</b>	REVISION LEVEL	A	PROJECTION

ALL DIMENSIONS AND TOLERANCES APPLY TO FINISHED PART IN INCHES.  
 ALLOWABLE TOLERANCES UNLESS SPECIFIED OTHERWISE: NONE ±0.5  
 X.X DECIMAL ±0.1 X.XX DECIMAL ±0.02 X.XXX DECIMAL ±0.005  
 ANGLES ±1 DEGREE SURFACE FINISH 128 microinch RMS