

.06 [1.5] MAXIMUM OVER/UNDERFILL,
NOT INCLUDING MENISCUS ON WIRES
WIRES TO EXIT WITHIN ϕ 1.25 [31.8],
SPACING CONTROL NOT REQUIRED
BOTH SIDES

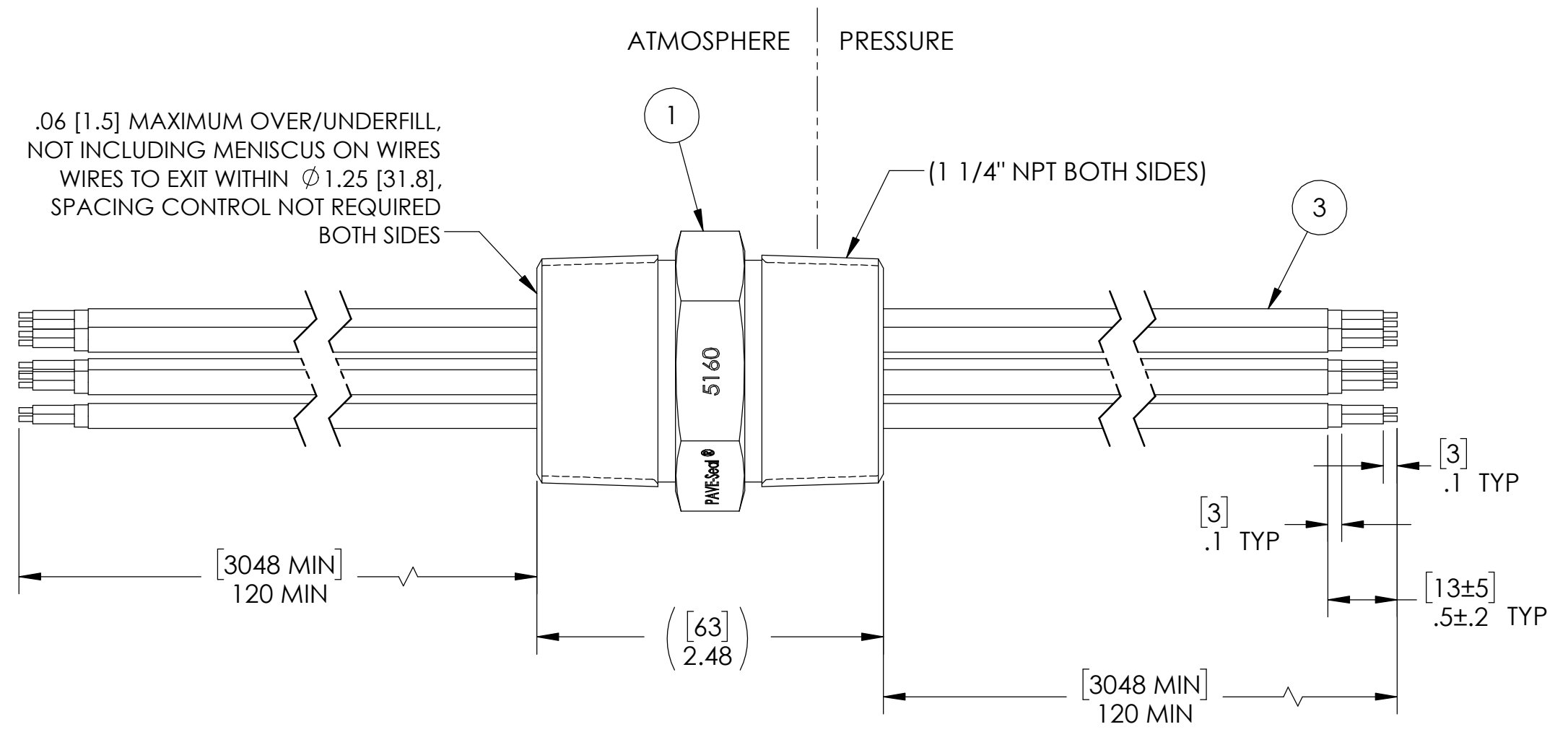

NOTES:

1. LEAK TEST: 500 PSI, NO BUBBLES 2 MINUTES MINIMUM. A GREEN PAINT DOT INDICATES THE PART HAS PASSED THE TEST.
2. HYPOT 630 VDC 500 MEGOHMS MINIMUM 0.01 SECOND MINIMUM WIRE TO WIRE TO SHIELD AND HOUSING.
3. CONTINUITY TEST SHIELDS < 0.5 OHM END TO END.
4. ALL TESTS ARE PERFORMED AT ROOM TEMPERATURE.
5. ALL PARTS MUST PASS ALL TESTS.
6. WIRE POSITIONING IS APPROXIMATE & VARIABLE.
7. COSMETIC SURFACE VOIDS NOT ON O-RING SEALING SURFACES ARE ACCEPTABLE BASED ON THE SEAL'S DIAMETER:
 <= .5 [12.7] SEAL DIAMETER: ϕ .035 [.89] MAX ALLOWED VOID SIZE
 > .5 [12.7] SEAL DIAMETER: ϕ .060 [1.5] MAX ALLOWED VOID SIZE
8. REF-OPERATING TEMPERATURE RANGE -46°C TO 125°C.
9. DIMENSIONS ARE INCHES [millimeters].
10. PAVE-SEAL CAN BE A BI-DIRECTIONAL HERMETIC SEAL FOR VACUUM AND MOST PRESSURES. FOR PRESSURES ABOVE 150 PSI (10 BAR), CHECK WITH SALES ENGINEERING.

ITEM	QTY	PART NUMBER	DESCRIPTION
3	8	TEF 3/C #18 TST	CABLE 3/C #18 M16878/4 SPC BRAID OVERALL PTFE WRAP
2	A/R	PAVE-Seal 150	EPOXY BLACK
1	1	3216	HOUSING PTN20-SS

PAVE technology co.
 2751 Thunderhawk Court
 Dayton, OH 45414-3445
 U.S.A.
 tel (937) 890-1100
 fax (937) 8905165
 www.pavetechnologyco.com

DESCRIPTION PTN20-SS-150-8-TST18-120-120	
PART NUMBER 5160	MATERIAL NOTED
REVISION LEVEL -	PROJECTION ☉ ◻

ALL DIMENSIONS AND TOLERANCES APPLY TO FINISHED PART IN INCHES.
 ALLOWABLE TOLERANCES UNLESS SPECIFIED OTHERWISE: NONE ±0.5
 X.X DECIMAL ±0.1 X.XX DECIMAL ±0.02 X.XXX DECIMAL ±0.005
 ANGLES ±1 DEGREE SURFACE FINISH 128 microinch RMS