

3852 & 3852-2: ATMOSPHERE PRESSURE
 3852-1 ONLY: PRESSURE VACUUM

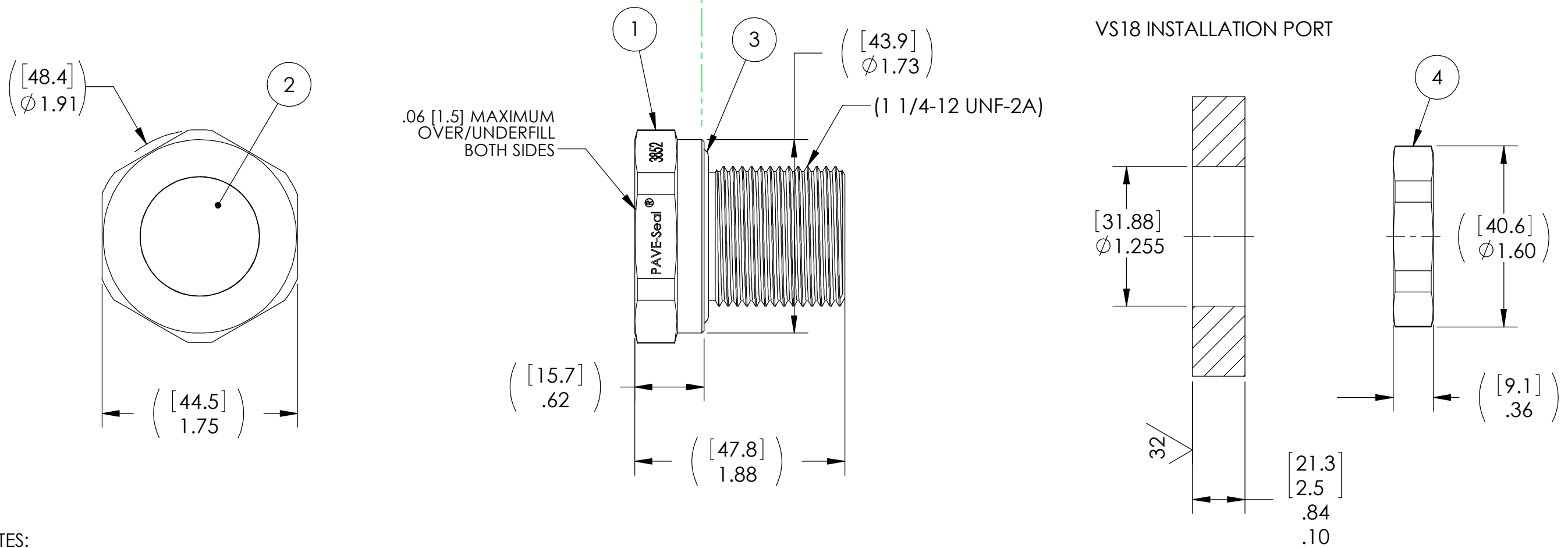

NOTES:

1. LEAK TEST AS FOLLOWS, A GREEN PAINT DOT ON THE HOUSING HEX INDICATES THE PART HAS PASSED THE SPECIFIED LEAK TEST:
 3852 ONLY: 1000 PSI, NO N2 BUBBLES 15 SECONDS MINIMUM.
 3852-1 ONLY: HE LEAK TEST @ 1500 PSI. 1X10⁻⁵ CC/SEC OR LESS FOR 5 MINUTES MINIMUM.
 3852-2 ONLY: 3200 PSI, NO N2 BUBBLES 15 SECONDS MINIMUM.
2. ALL TESTS ARE PERFORMED AT ROOM TEMPERATURE.
3. ALL PARTS MUST PASS ALL TESTS.
4. COSMETIC SURFACE VOIDS NOT ON O-RING SEALING SURFACES ARE ACCEPTABLE BASED ON THE SEAL'S DIAMETER:
 <= .5 [12.7] SEAL DIAMETER: ϕ .035 [.89] MAX ALLOWED VOID SIZE
 > .5 [12.7] SEAL DIAMETER: ϕ .060 [1.5] MAX ALLOWED VOID SIZE
5. REF-OPERATING TEMPERATURE RANGE -40 °C TO 107 °C.
6. PAVE-SEAL CAN BE A BI-DIRECTIONAL HERMETIC SEAL FOR VACUUM AND MOST PRESSURES. FOR PRESSURES ABOVE 150 PSI (10 BAR), CHECK WITH SALES ENGINEERING.
7. DIMENSIONS ARE INCHES [millimeters].
8. ALCOHOL OR FOMBLIN YVAC 3 MAY BE USED TO LUBRICATE O-RINGS FOR HELIUM LEAK TESTING.

4	1	1014	NUT VS18-SS
3	1	-219 NITRILE LT	O-RING -219 NITRILE 75 LOW-TEMP
2	A/R	PAVE-Seal 150	EPOXY BLACK
1	1	0660	HOUSING VS18-SS
ITEM	QTY	PART NUMBER	DESCRIPTION

PAVE technology co.
 2751 Thunderhawk Court
 Dayton, OH 45414-3445
 U.S.A.
 tel (937) 890-1100
 fax (937) 8905165
 www.pavetechnologyco.com

DESCRIPTION
 VS18-SS-150-PLUG

PART NUMBER *SEE NOTE 1
3852*

MATERIAL NOTED
 REVISION LEVEL D
 PROJECTION

ALL DIMENSIONS AND TOLERANCES APPLY TO FINISHED PART IN INCHES.
 ALLOWABLE TOLERANCES UNLESS SPECIFIED OTHERWISE: NONE ±0.5
 X.X DECIMAL ±0.1 X.XX DECIMAL ±0.02 X.XXX DECIMAL ±0.005
 ANGLES ±1 DEGREE SURFACE FINISH 128 microinch RMS