

REF-MATING CONNECTORS  
SCALE: 1:2

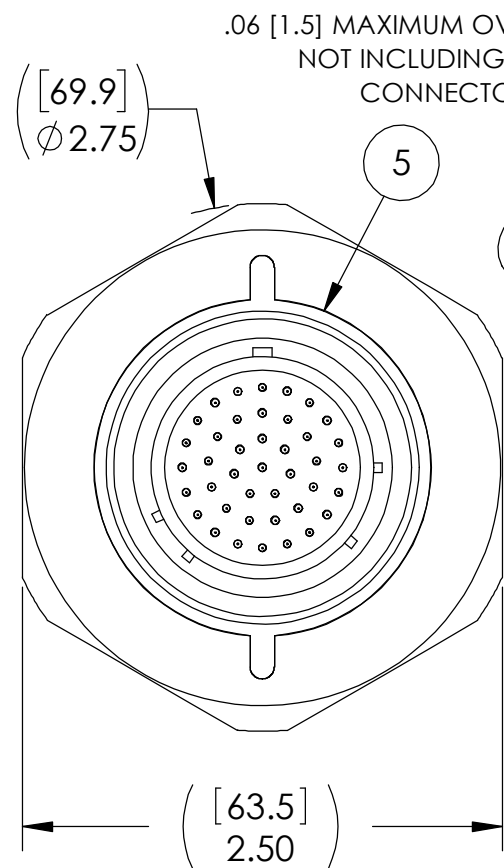

ATMOSPHERE | VACUUM

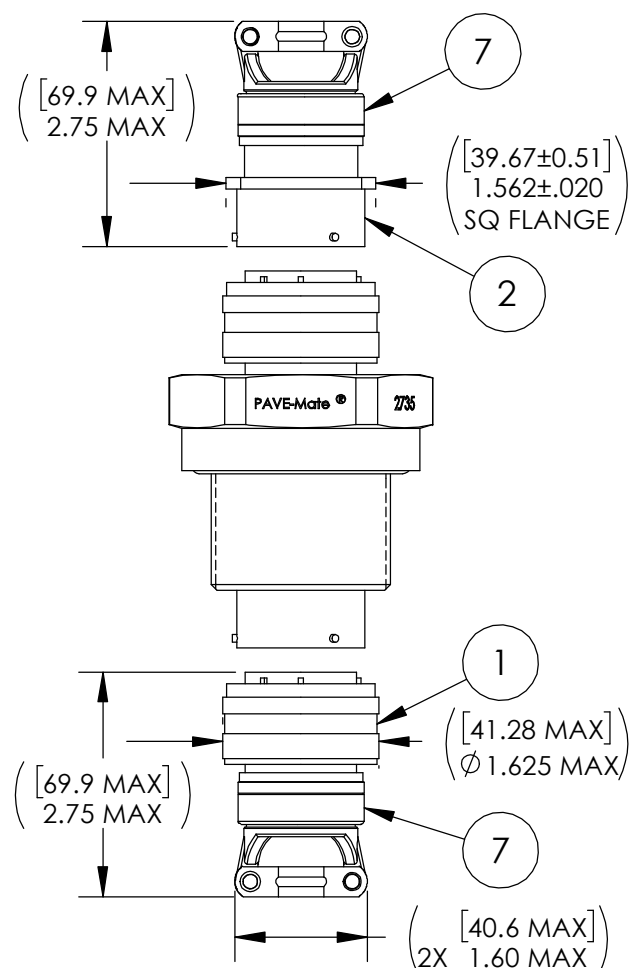
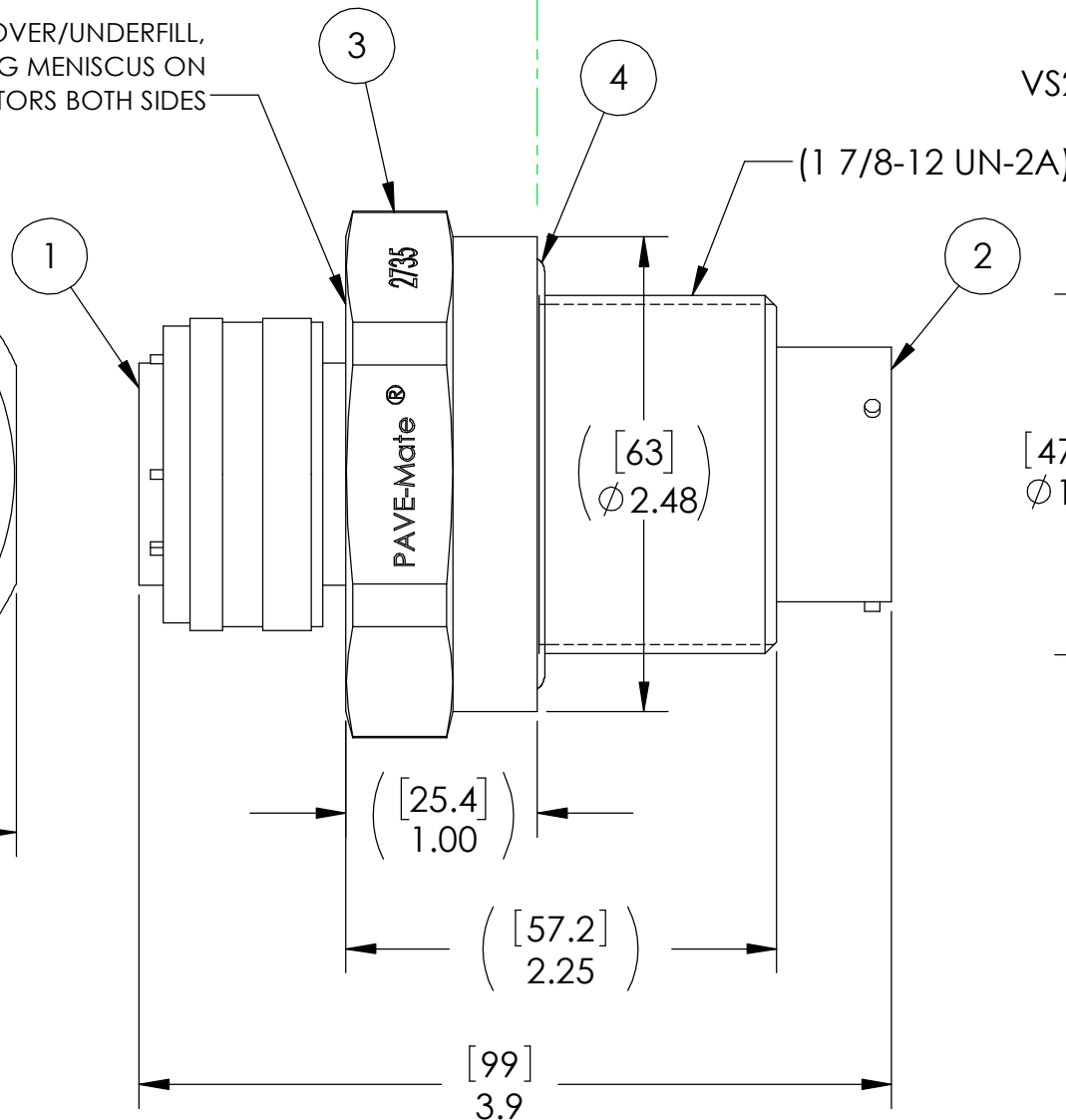

VS26 INSTALLATION PORT

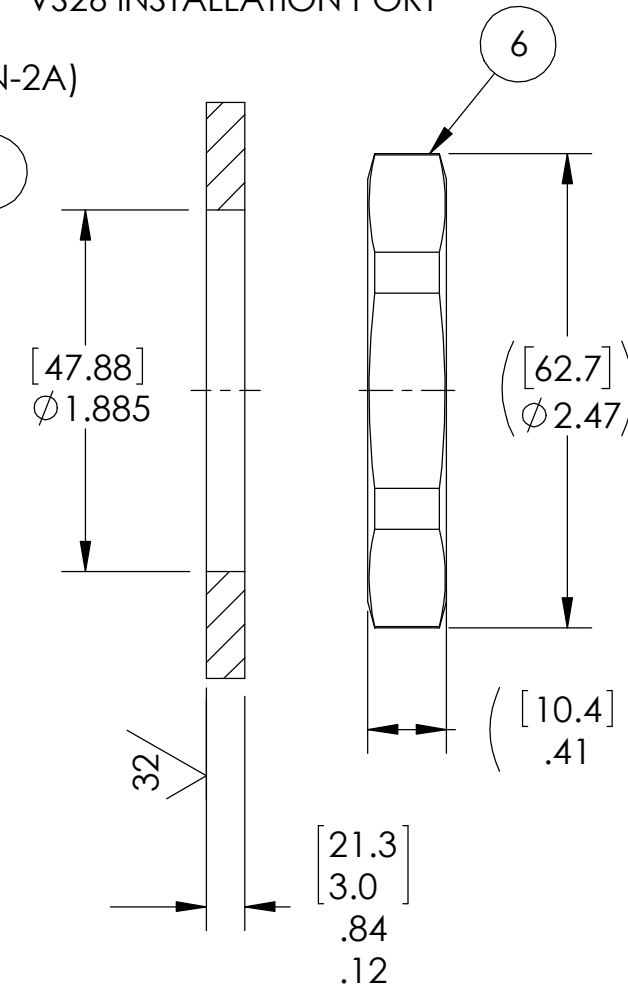

NOTES:

1. HE LEAK TEST @ 1 ATM. 5X10<sup>-8</sup> CC/SEC OR LESS. A GREEN PAINT DOT ON THE ATMOSPHERE SIDE INDICATES THE PART HAS PASSED THE TEST.
2. HYPOT 1000 VDC 500 MEGOHMS MINIMUM 0.01 SECOND MINIMUM PIN TO PIN AND HOUSING WITH MATING CONNECTORS.
3. CONTINUITY TEST <0.5 OHM PIN TO SOCKET WITH MATING CONNECTORS.
4. ALL TESTS ARE PERFORMED AT ROOM TEMPERATURE.
5. ALL PARTS MUST PASS ALL TESTS.
6. REF-OPERATING TEMPERATURE RANGE -20°C TO 125°C.
7. SHELLS FOR ITEMS 1 & 2, AND HOUSING (ITEM 3) ARE TO HAVE ELECTRICAL CONTINUITY.
8. ALCOHOL OR FOMBLIN YVAC 3 MAY BE USED TO LUBRICATE O-RINGS FOR VACUUM HELIUM LEAK TESTING.
9. COSMETIC SURFACE VOIDS NOT ON O-RING SEALING SURFACES ARE ACCEPTABLE BASED ON THE SEAL'S DIAMETER:  
 <= .5 [12.7] SEAL DIAMETER:  $\phi$ .035 [.89] MAX ALLOWED VOID SIZE  
 > .5 [12.7] SEAL DIAMETER:  $\phi$ .060 [1.5] MAX ALLOWED VOID SIZE
10. DIMENSIONS ARE INCHES [millimeters].
11. PAVE-SEAL CAN BE A BI-DIRECTIONAL HERMETIC SEAL FOR VACUUM AND MOST PRESSURES. FOR PRESSURES ABOVE 150 PSI (10 BAR), CHECK WITH SALES ENGINEERING.

ITEM	QTY	PART NUMBER	DESCRIPTION
7	2	M85049/49-2-20N	STRAIN RELIEF 38999 SERIES I/II SHELL 20/21 NICKEL PLATED ALUMINUM
6	1	0185	NUT VS26-SS
5	A/R	PAVE-Seal 150	EPOXY BLACK
4	1	-226 VITON	O-RING -226 VITON 75
3	1	3664	HOUSING VS26-SS
2	2	MS27466T21F41S	RCPT 41#20 SOCKET 999 SERIES I NICKEL PLATED ALUMINUM SHELL GOLD PLATED CRIMP CONTACTS
1	2	MS27467T21F41P	PLUG 41#20 PIN 999 SERIES I NICKEL PLATED ALUMINUM SHELL GOLD PLATED CRIMP CONTACTS

ALL DIMENSIONS AND TOLERANCES APPLY TO FINISHED PART IN INCHES.  
 ALLOWABLE TOLERANCES UNLESS SPECIFIED OTHERWISE: NONE ±0.5  
 X.X DECIMAL ±0.1 X.XX DECIMAL ±0.02 X.XXX DECIMAL ±0.005  
 ANGLES ±1 DEGREE. SURFACE FINISH 128 microinch RMS

**PAVE technology co.**  
 2751 Thunderhawk Court  
 Dayton, OH 45414-3445  
 U.S.A.  
 tel (937) 890-1100  
 fax (937) 8905165  
 www.pavetechnologyco.com

DESCRIPTION  
 VS26-SS-150-41-20-27466PS

PART NUMBER  
**2735**

MATERIAL NOTED

REVISION LEVEL  
 B

PROJECTION