

ATMOSPHERE / FEMALE
PIN LOCATION
SCALE: 3:1

ATMOSPHERE	VACUUM
PIN1	PIN1
PIN2	PIN2
PIN3	PIN3
PIN4	PIN4

PIN-OUT CHART

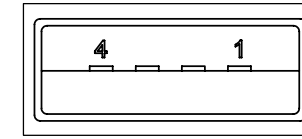

VACUUM / MALE
PIN LOCATION
SCALE: 3:1

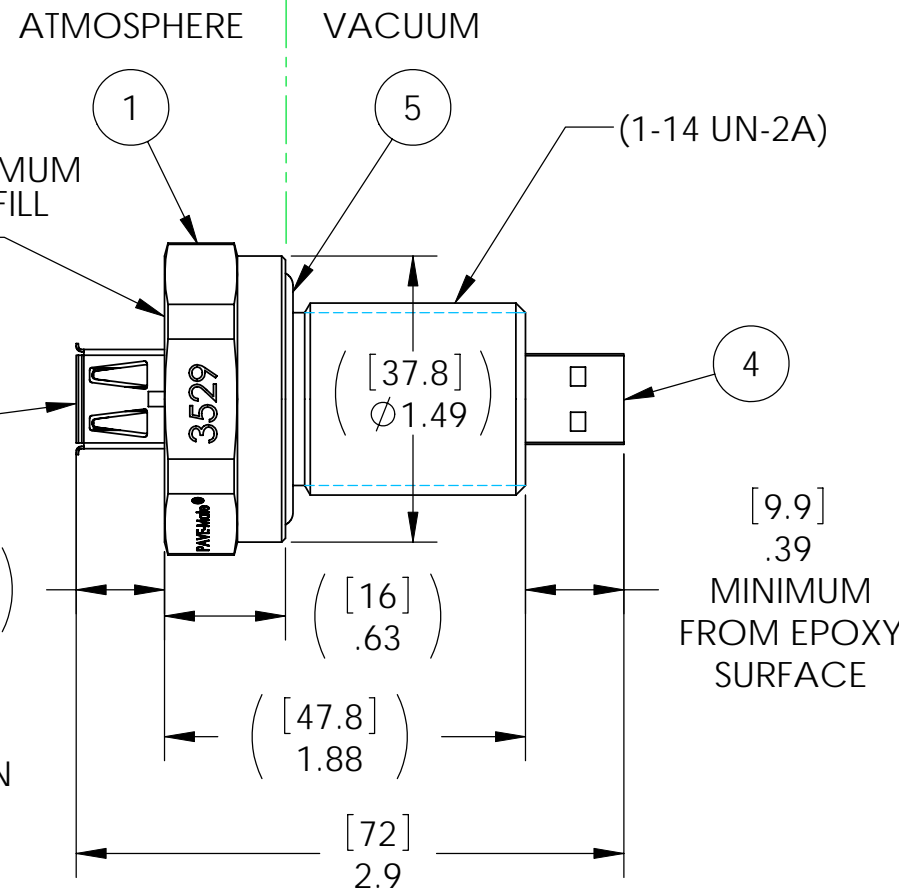
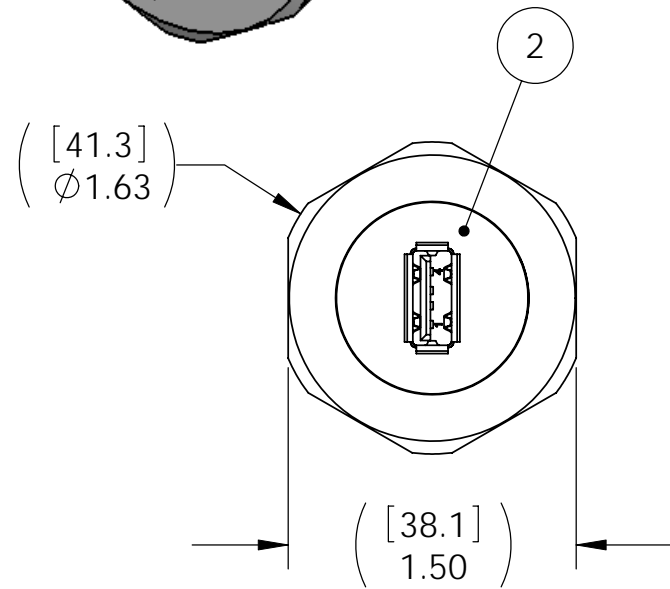

VS15L INSTALLATION PORT

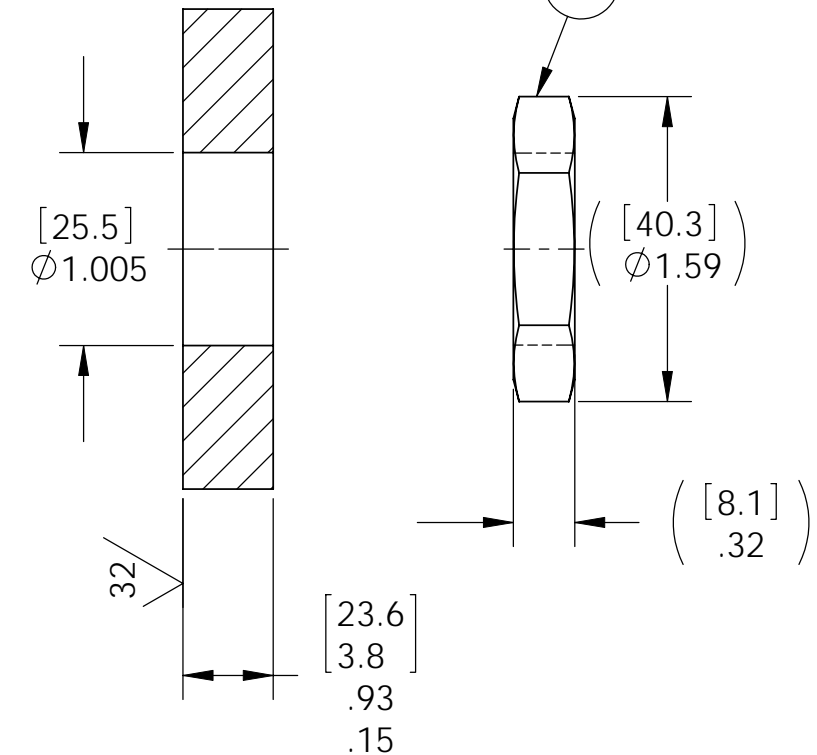

NOTES:

1. HE LEAK TEST @ 1ATM. 1X10⁻⁶ CC/SEC OR LESS. A GREEN PAINT DOT INDICATES THE PART HAS PASSED THE TEST.
2. HYPOT 630 VDC 500 MEGOHMS MINIMUM 0.01 SECOND MINIMUM PIN TO PIN AND HOUSING WITH MATING CONNECTORS.
3. CONTINUITY CHECK <.5Ω PIN TO PIN PER CHART.
4. ALL TESTS ARE PERFORMED AT ROOM TEMPERATURE.
5. ALL PARTS MUST PASS ALL TESTS.
6. COSMETIC SURFACE VOIDS LARGER THAN Ø .035 [0.89] ARE NOT ACCEPTABLE.
7. REF-OPERATING TEMPERATURE RANGE OF USB CONNECTORS (ITEMS 3 AND 4) -55°C TO 85°C. SEE TABLE FOR REF-OPERATING TEMPERATURE RANGE OF SEAL.
8. DIMENSIONS ARE INCHES [millimeters].
9. PAVE-SEAL CAN BE A BI-DIRECTIONAL HERMETIC SEAL FOR VACUUM AND MOST PRESSURES. FOR PRESSURES ABOVE 150 PSI (10 BAR), CHECK WITH SALES ENGINEERING.
10. ALCOHOL OR FOMBLIN YVAC 3 MAY BE USED TO LUBRICATE O-RINGS FOR VACUUM HELIUM LEAK TESTING.

PAVE#	ITEM 5 PART#	ITEM 5 DESCRIPTION	(SEAL TEMP RANGE)
3529	-215 VITON	O-RING -215 VITON 75	-20°C TO 125°C
3529-1	-215 NM304-75	O-RING -215 NITRILE LOW TEMP 75	-53°C TO 107°C

ITEM	QTY	PART NUMBER	DESCRIPTION
6	1	0183	NUT VS15-SS
5	1	SEE TABLE	SEE TABLE
4	1	KUSBX-SMT2AP1S-B30	PLUG USB A-TYPE SMT 4 POS 30u" Au
3	1	KUSBVX-AS-1-N-B30	RCPT USB A-TYPE PCBV 4 POS 30u" Au
2	A/R	PAVE-Seal 150	EPOXY BLACK
1	1	0161	HOUSING VS15L-SS

PAVE technology co.

2751 Thunderhawk Court
Dayton, OH 45414-3445
U.S.A.
tel (937) 890-1100
fax (937) 8905165
www.pavetechnologyco.com

DESCRIPTION
VS15L-SS-150-1-USBAmale-USBAfemale

PART NUMBER *SEE TABLE MATERIAL NOTED

3529*

REVISION LEVEL C PROJECTION

ALL DIMENSIONS AND TOLERANCES APPLY TO FINISHED PART IN INCHES.
ALLOWABLE TOLERANCES UNLESS SPECIFIED OTHERWISE: NONE ±0.5
X.X DECIMAL ±0.1 X.XX DECIMAL ±0.02 X.XXX DECIMAL ±0.005
ANGLES ±1 DEGREE SURFACE FINISH 128 microinch RMS