

WIRING DIAGRAM	
PIN NO.	AWG & COLOR
1	18 AWG WHT
2	26 AWG VIO
3	26 AWG ORN
4	26 AWG BLU
5	26 AWG BRN
6	18 AWG RED
7	18 AWG BLK
8	26 AWG YEL
9	26 AWG GRN

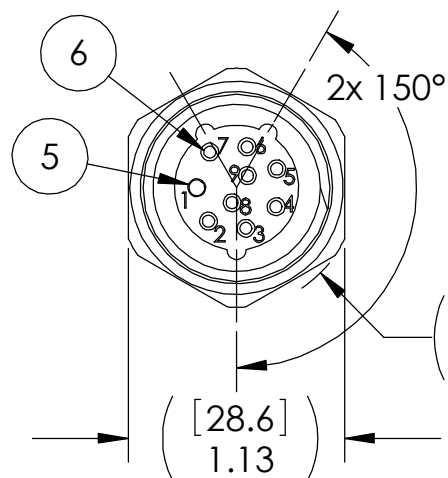

NUMBERS SHOWN FOR WIRING ONLY & WILL NOT BE ON MOLDED ASSEMBLY. CABLE NOT SHOWN THIS VIEW FOR CLARITY.

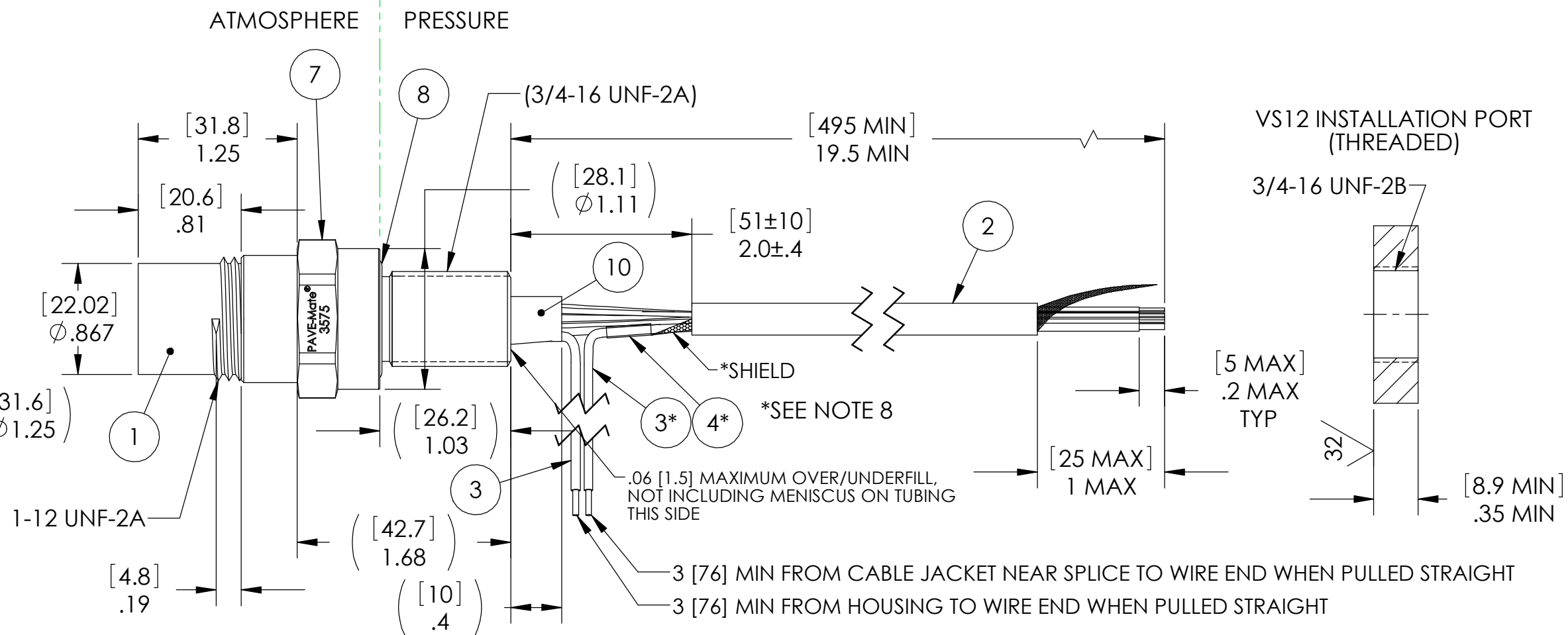

NOTES:

- LEAK TEST: 80 PSI, NO BUBBLES 2 MINUTES MINIMUM. A GREEN PAINT DOT ON THE ATMOSPHERE SIDE INDICATES THE PART HAS PASSED THE TEST.
- HYPOT 630 VDC 500 MEGOHMS MINIMUM 0.01 SECOND MINIMUM WIRE TO WIRE AND HOUSING.
- CONTINUITY TEST <0.5 OHM MATING CONNECTOR TO WIRE ENDS AND LAP SOLDERED 18AWG WHITE WIRE TO SHEILD AND CABLE 18AWG WHITE WIRE.
- ALL TESTS ARE PERFORMED AT ROOM TEMPERATURE.
- ALL PARTS MUST PASS ALL TESTS.
- COSMETIC SURFACE VOIDS NOT ON O-RING SEALING SURFACES ARE ACCEPTABLE BASED ON THE SEAL'S DIAMETER:
 <= .5 [12.7] SEAL DIAMETER: ϕ .035 [.89] MAX ALLOWED VOID SIZE
 > .5 [12.7] SEAL DIAMETER: ϕ .060 [1.5] MAX ALLOWED VOID SIZE
- REF-OPERATING TEMPERATURE RANGE -40°C TO 105°C.
- ITEM 3 (PC18 WHITE), CABLE SHIELD, AND 18AWG WHITE WIRE FROM CABLE LAP SOLDERED UNDER ITEM 4 (SHRINK TUBING).
- ITEM 9 (NOT SHOWN) IS A PLASTIC DUST CAP SHIPPED INSTALLED ON ASSEMBLY.
- PAVE-SEAL CAN BE A BI-DIRECTIONAL HERMETIC SEAL FOR VACUUM AND MOST PRESSURES. FOR PRESSURES ABOVE 150 PSI (10 BAR), CHECK WITH SALES ENGINEERING.

10	1	TFT-200-1	TUBING TEFLON .294 ID THIN WALL
9	1	EC-14	CAPLUG MS90376-14R OR EQUAL
8	1	-116 VITON LT	O-RING -116 VITON 75
7	1	3808	HOUSING VS12XL-AL
6	8	201570	CONTACT .062" X .472 PIN
5	1	5231-0-00	CONTACT .093" X .505 PIN
4	1	FIT-221-1/8	TUBING SHRINK 1/8" IRR POLY MIL-1-23053/5-104-0 BLACK
3	2	PC18 1569 WHT16	WIRE 18PC UL1569/1007 CSA TR64
2	1	CW5262	CABLE 3/6C #18/26 SHIELDED PVC
1	A/R	PAVE-Seal 150	EPOXY BLACK
ITEM	QTY	PART NUMBER	DESCRIPTION

PAVE technology co.
 2751 Thunderhawk Court
 Dayton, OH 45414-3445
 U.S.A.
 tel (937) 890-1100
 fax (937) 8905165
 www.pavetechnologyco.com

DESCRIPTION
 VS12XL-AL-150-3/6-PC18/26-RCPT-20

PART NUMBER
3575

MATERIAL NOTED

REVISION LEVEL
 N

PROJECTION

ALL DIMENSIONS AND TOLERANCES APPLY TO FINISHED PART IN INCHES.
 ALLOWABLE TOLERANCES UNLESS SPECIFIED OTHERWISE: NONE ±0.5
 X.X DECIMAL ±0.1 X.XX DECIMAL ±0.02 X.XXX DECIMAL ±0.005
 ANGLES ±1 DEGREE SURFACE FINISH 128 microinch RMS