

RECOMMENDED RETAINING RING
TRUARC N5000-56 OR EQUAL

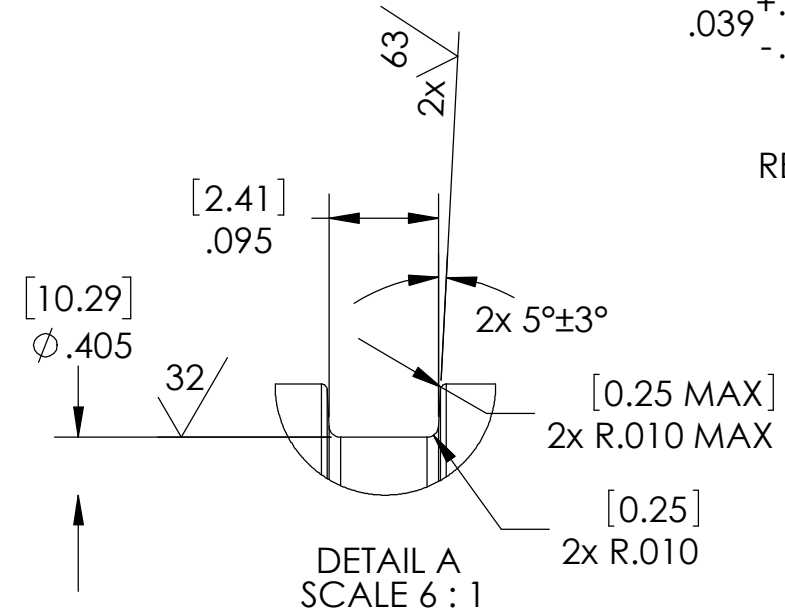

- NOTES:
- QUALIFICATION TESTS:
 - LEAK TEST: 150 PSI (AIR), NO BUBBLES 10 SECONDS MINIMUM.
 - HYPOT 1500 VAC, 0.5mA MAX LEAKAGE, 60 SECONDS MINIMUM, WIRE TO WIRE & INSTALLATION PORT.
 - PRODUCTION TESTS:
 - LEAK TEST: 80 PSI (AIR), NO BUBBLES 10 SECONDS MINIMUM. A GREEN PAINT DOT INDICATES THE PART HAS PASSED THE LEAK TEST.
 - HYPOT 1000 VDC 100 MEGOHMS MINIMUM 0.01 SECONDS MINIMUM WIRE TO WIRE.
 - ALL TESTS ARE PERFORMED AT ROOM TEMPERATURE.
 - ALL PARTS MUST PASS ALL TESTS.
 - COSMETIC SURFACE VOIDS NOT ON O-RING SEALING SURFACES ARE ACCEPTABLE BASED ON THE SEAL'S DIAMETER:
 - $\leq .5$ [12.7] SEAL DIAMETER: ϕ .035 [.89] MAX ALLOWED VOID SIZE
 - $> .5$ [12.7] SEAL DIAMETER: ϕ .060 [1.5] MAX ALLOWED VOID SIZE
 - ENVIRONMENTAL SPECIFICATIONS (REFERENCE)
 - OPERATING TEMPERATURE -20 °C TO 200 °C.
 - STORAGE TEMPERATURE -40 °C TO 200 °C.
 - REF-PARTS ARE DEFLASHED ON PARTING LINE +.005 [0.13] MAX.
 - DIMENSIONS ARE INCHES [millimeters].
 - CUT INSULATION PER DIMENSION SHOWN, IT IS ACCEPTABLE FOR 4X RETAINED ENDS (SLUGS) TO BE LOST DURING HANDLING.

5	A/R	PARKER O-LUBE	LUBRICANT O-RING BARIUM BASED
4	2	-012 VITON	O-RING -012 VITON 75
3	1	EE18 BLACK	WIRE 18EE MIL-W-16878/5 .015
2	1	EE18 RED	WIRE 18EE MIL-W-16878/5 .015
1	A/R	PAVE-Seal 200UL94	EPOXY BLACK
ITEM	QTY	PART NUMBER	DESCRIPTION

PAVE technology co.

2751 Thunderhawk Court
Dayton, OH 45414-3445
U.S.A.
tel (937) 890-1100
fax (937) 8905165
www.pavetechnologyco.com

DESCRIPTION
SP8C-E-200UL94-2-TEE18-3-4

PART NUMBER
3578

MATERIAL NOTED

REVISION LEVEL
G

PROJECTION

ALL DIMENSIONS AND TOLERANCES APPLY TO FINISHED PART IN INCHES.
ALLOWABLE TOLERANCES UNLESS SPECIFIED OTHERWISE: NONE ±0.5
XX DECIMAL ±0.1 X.XX DECIMAL ±0.02 X.XXX DECIMAL ±0.005
ANGLES ±1 DEGREE SURFACE FINISH 128 microinch RMS