

PAVE#	X	Y	TIME	ITEM 4	ITEM 4 DESCRIPTION	ITEM 5	ITEM 5 DESCRIPTION	TEMPERATURE
4419	12 [305]	12 [305]	30 SECONDS	-012 VITON	O-RING -012 VITON 75	PARKER O-LUBE	LUBRICANT O-RING BARIUM-BASED	-20°C TO 125°C
4419-1	118 [2997]	6 [152]	1 MINUTE	-012 VITON LT	O-RING -012 LOW-TEMP VITON 75	FOMBLIN YVAC 3	LUBRICANT O-RING FOMBLIN GREASE	-40°C TO 125°C

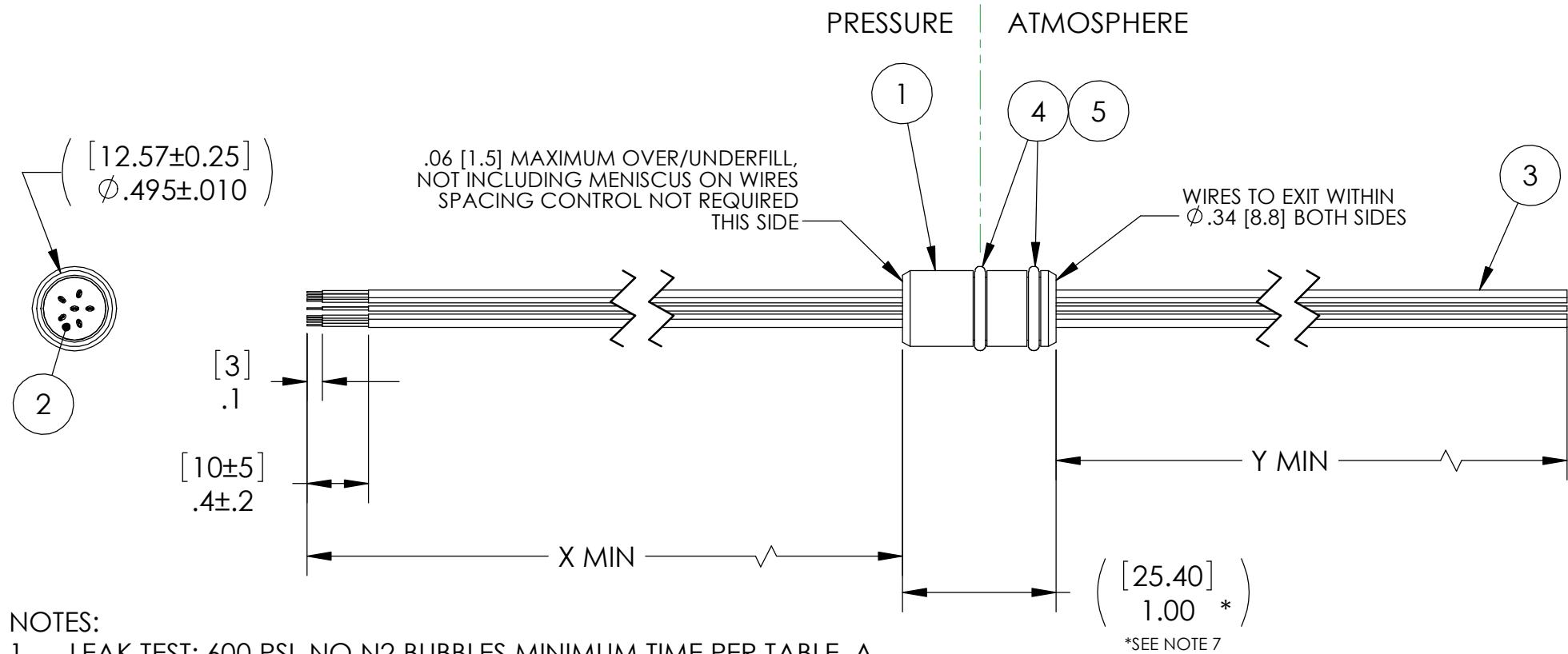

NOTES:

- LEAK TEST: 600 PSI, NO N2 BUBBLES MINIMUM TIME PER TABLE. A GREEN PAINT DOT INDICATES THE PART HAS PASSED THE TEST.
- HYPOT 630 VDC 500 MEGOHMS MINIMUM 0.01 SECOND MINIMUM WIRE TO WIRE.
- ALL TESTS ARE PERFORMED AT ROOM TEMPERATURE.
- ALL PARTS MUST PASS ALL TESTS.
- WIRE POSITIONING IS APPROXIMATE & VARIABLE.
- COSMETIC SURFACE VOIDS NOT ON O-RING SEALING SURFACES ARE ACCEPTABLE BASED ON THE SEAL'S DIAMETER:
 <= .5 [12.7] SEAL DIAMETER: Ø.035 [.89] MAX ALLOWED VOID SIZE
 > .5 [12.7] SEAL DIAMETER: Ø.060 [1.5] MAX ALLOWED VOID SIZE
- DIMENSION IS OVER-ALL-LENGTH EXCLUDING OVERFILL ON PRESSURE SIDE OF HOUSING.
- REF-OPERATING TEMPERATURE RANGE PER TABLE.
- REF-PARTS ARE DEFLASHED ON PARTING LINE +0.005 MAXIMUM.
- PAVE-SEAL CAN BE A BI-DIRECTIONAL HERMETIC SEAL FOR VACUUM AND MOST PRESSURES. FOR PRESSURES ABOVE 150 PSI (10 BAR), CHECK WITH SALES ENGINEERING.
- DIMENSIONS ARE INCHES [millimeters].

ALL DIMENSIONS AND TOLERANCES APPLY TO FINISHED PART IN INCHES.
 ALLOWABLE TOLERANCES UNLESS SPECIFIED OTHERWISE: NONE ±0.5
 X.X DECIMAL ±0.1 X.XX DECIMAL ±0.02 X.XXX DECIMAL ±0.005
 ANGLES ±1 DEGREE SURFACE FINISH 128 microinch RMS

5	A/R	SEE TABLE	SEE TABLE
4	2	SEE TABLE	SEE TABLE
3	6	KT30	CABLE T/C TYPE K 30AWG FEP TEFLON
2	A/R	PAVE-Seal 150	EPOXY BLACK
1	1	1226L	HOUSING SP8L-E
ITEM	QTY	PART #	DESCRIPTION

SP8L INSTALLATION PORT

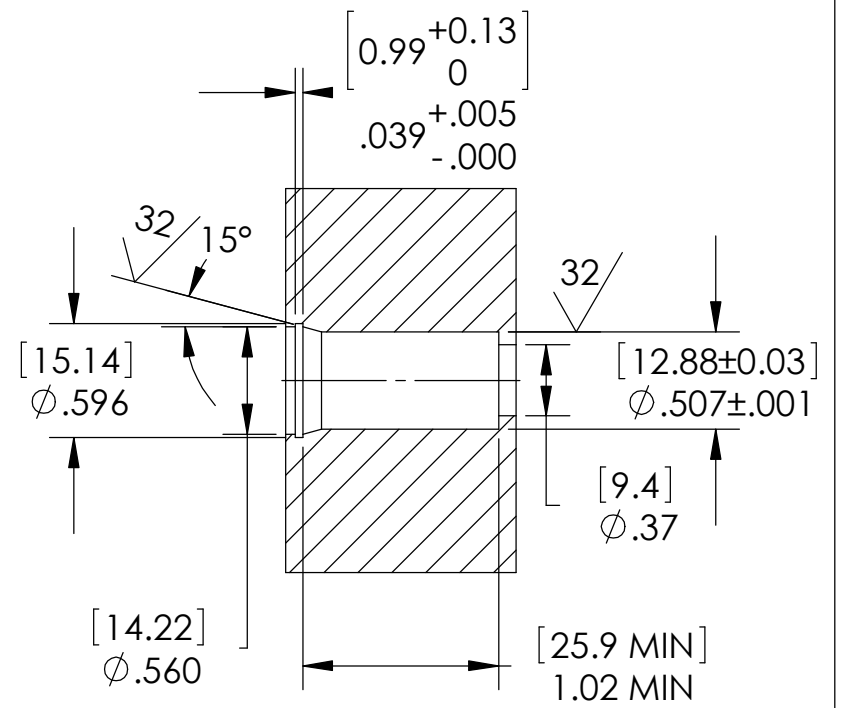

RECOMMENDED RETAINING RING
 TRUARC #5000-56 OR EQUAL

PAVE technology co.
 2751 Thunderhawk Court
 Dayton, OH 45414-3445
 U.S.A.
 tel (937) 890-1100
 fax (937) 8905165
 www.pavetechnologyco.com

DESCRIPTION
 SP8L-E-150-6P-KT30-X-Y

PART NUMBER
4419

MATERIAL NOTED

REVISION LEVEL
 B

PROJECTION