

RECOMMENDED RETAINING RING
TRUARC N5000-43 OR EQUAL

ADDITIONAL HOUSING DETAILS
(O-RINGS & BACKUP RING REMOVED FOR CLARITY)

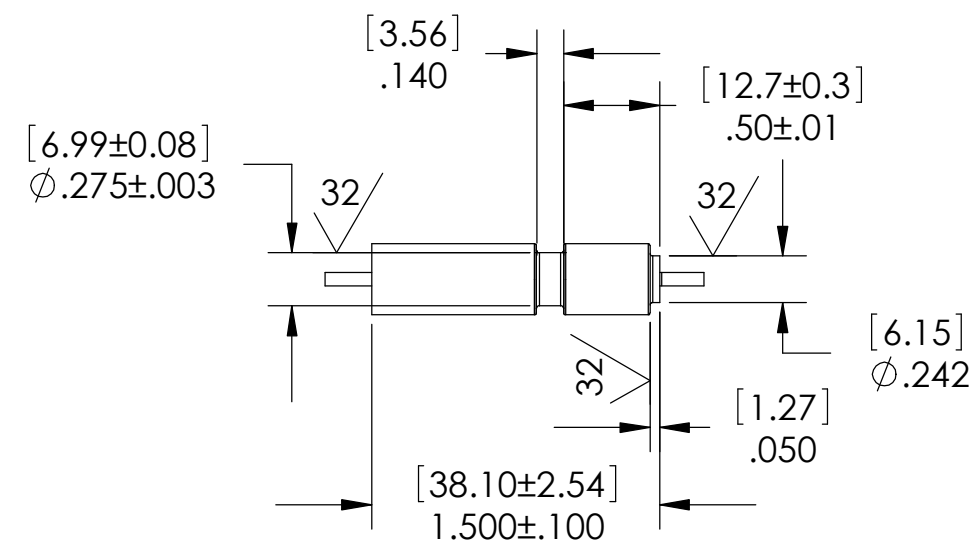

PAVE#	PRESSURE
4792	10,000 PSI
4792-1	4,500 PSI

NOTES:

- LEAK TEST: PRESSURE PER TABLE, NO N2 BUBBLES 30 SECONDS MINIMUM. A GREEN PAINT DOT ON THE PRESSURE SIDE INDICATES THE PART HAS PASSED THE TEST.
- REF-CUSTOMER QUALIFICATION TEST: 24,000 PSI BURST.
- HYPOT 630 VDC 500 MEGOHMS MINIMUM 0.01 SECOND MINIMUM CENTER CONDUCTOR TO SHIELD.
- ALL TESTS ARE PERFORMED AT ROOM TEMPERATURE.
- ALL PARTS MUST PASS ALL TESTS.
- WIRE POSITIONING IS APPROXIMATE & VARIABLE.
- COSMETIC SURFACE VOIDS NOT ON O-RING SEALING SURFACES ARE ACCEPTABLE BASED ON THE SEAL'S DIAMETER:
 $\leq .5$ [12.7] SEAL DIAMETER: $\phi .035$ [.89] MAX ALLOWED VOID SIZE
 $> .5$ [12.7] SEAL DIAMETER: $\phi .060$ [1.5] MAX ALLOWED VOID SIZE
- REF-OPERATING TEMPERATURE RANGE -20°C TO 125°C .
- DIMENSIONS ARE INCHES [millimeters].
- PAVE-SEAL CAN BE A BI-DIRECTIONAL HERMETIC SEAL FOR VACUUM AND MOST PRESSURES. FOR PRESSURES ABOVE 150 PSI (10 BAR), CHECK WITH SALES ENGINEERING.

ITEM	QTY	PART NUMBER	DESCRIPTION
5	A/R	PARKER O-LUBE	LUBRICANT O-RING BARIUM-BASED
4	1	B/U RING -010	BACK UP RING -010 SINGLE TURN PER MS28774
3	2	-010 VITON	O-RING -010 VITON 75
2	1	RG178	WIRE COAX M17/93 FEP/TFE 7#38 SPCS
1	A/R	PAVE-Seal 150	EPOXY BLACK

PAVE technology co.
 2751 Thunderhawk Court
 Dayton, OH 45414-3445
 U.S.A.
 tel (937) 890-1100
 fax (937) 8905165
 www.pavetechnologyco.com

DESCRIPTION
SP6H-E-150-1-RG178-18-18

PART NUMBER *SEE TABLE MATERIAL NOTED
4792*

REVISION LEVEL A PROJECTION

ALL DIMENSIONS AND TOLERANCES APPLY TO FINISHED PART IN INCHES.
 ALLOWABLE TOLERANCES UNLESS SPECIFIED OTHERWISE: NONE ± 0.5
 X.X DECIMAL ± 0.1 X.XX DECIMAL ± 0.02 X.XXX DECIMAL ± 0.005
 ANGLES ± 1 DEGREE. SURFACE FINISH 128 microinch RMS