

ATMOSPHERE | VACUUM

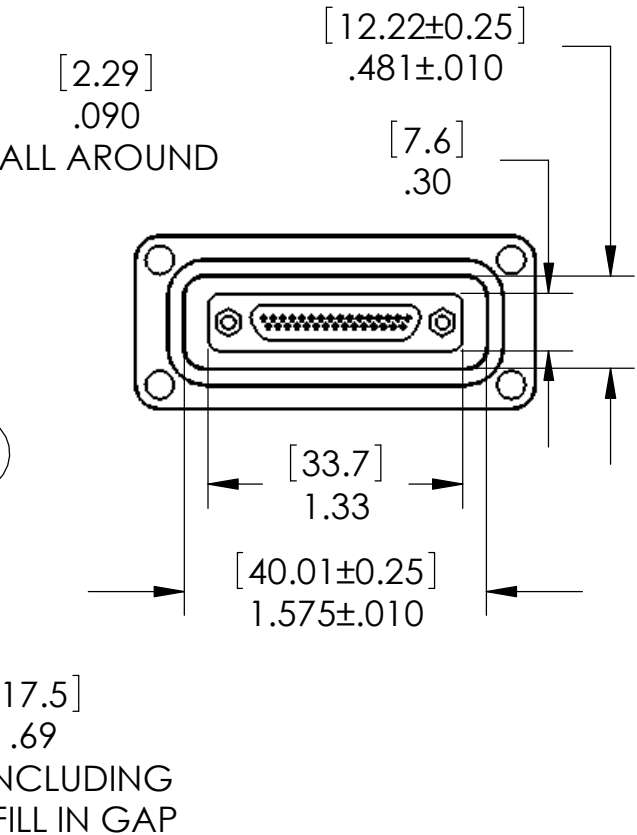

SP33/14 INSTALLATION PORT

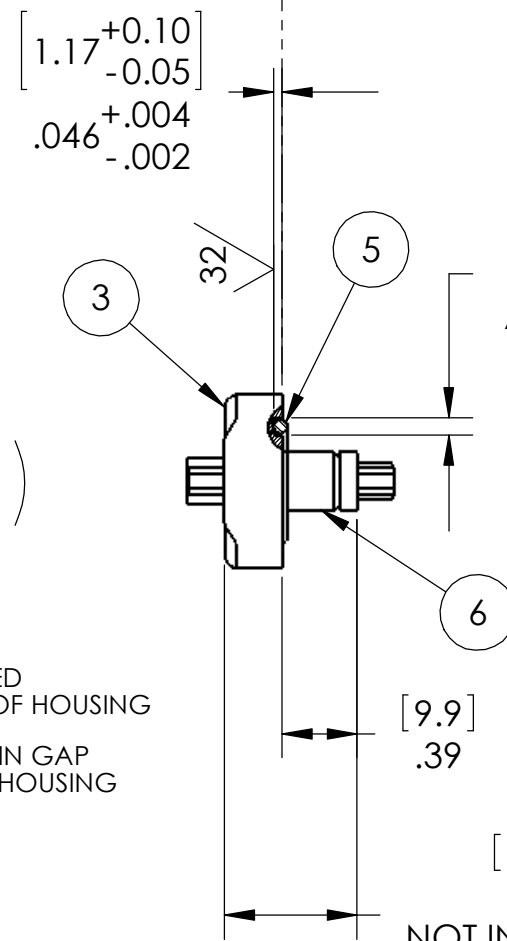
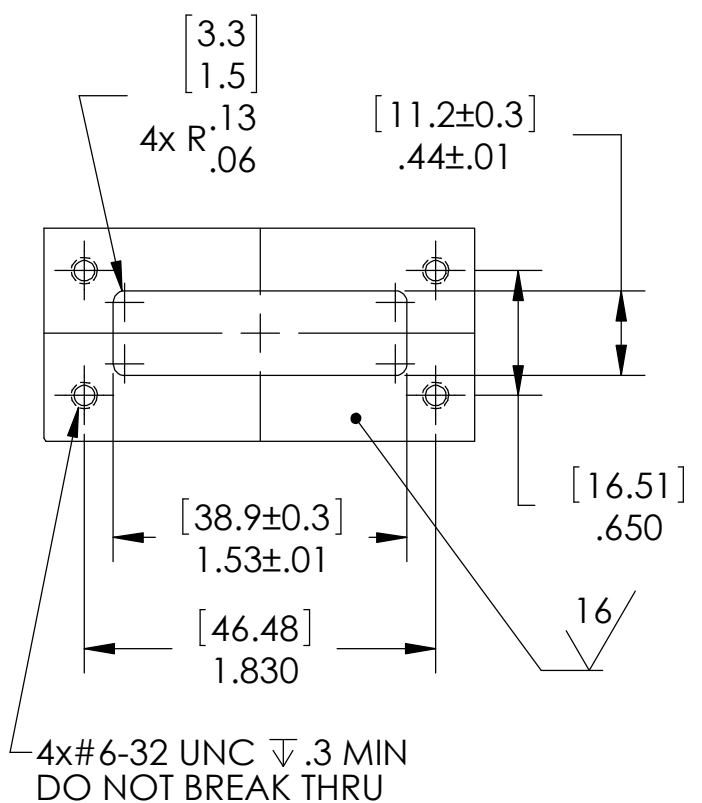

NOTES:

- HE LEAK TEST @ 1 ATM 1x10⁻⁸ CC/SEC OR LESS. A GREEN PAINT DOT INDICATES THE PART HAS PASSED THE TEST.
- HYPOT 500 VDC 200 MEGOHMS MINIMUM 0.01 SECOND MINIMUM WIRE TO WIRE AND HOUSING.
- CONTINUITY TEST 0.5 OHMS MAXIMUM MATING CONNECTOR TO MATING CONNECTOR.
- ALCOHOL OR FOMBLIN YVAC 3 MAY BE USED TO LUBRICATE O-RINGS FOR VACUUM HELIUM LEAK TESTING.
- ALL TESTS ARE PERFORMED AT ROOM TEMPERATURE.
- ALL PARTS MUST PASS ALL TESTS.
- COSMETIC SURFACE VOIDS NOT ON O-RING SEALING SURFACES ARE ACCEPTABLE BASED ON THE SEAL'S DIAMETER:
 <= .5 [12.7] SEAL DIAMETER: ϕ .035 [.89] MAX ALLOWED VOID SIZE
 > .5 [12.7] SEAL DIAMETER: ϕ .060 [1.5] MAX ALLOWED VOID SIZE
- REF-OPERATING TEMPERATURE -20°C TO 125°C.
- DIMENSIONS ARE INCHES [millimeters].
- PAVE# 5274R IS REVERSED WITH SOCKETS ON THE VACUUM SIDE AND PINS ON THE ATMOSPHERE SIDE.

ITEM	QTY	PART NUMBER	DESCRIPTION
6	A/R	PAVE-Seal 150	EPOXY BLACK
5	1	-026 VITON	O-RING -026 VITON 75
4	4	JACKPOST 2-56	"P" STYLE 2-56 UNC
3	1	3174	HOUSING SP33/14-AL 6061 ELECTROLESS NICKEL PLATED
2	1	MICROD 31P	CONNECTOR 31PIN MIL-C-83513
1	1	MICROD 31S	CONNECTOR 31SOC MIL-C-83513

PAVE technology co.
 2751 Thunderhawk Court
 Dayton, OH 45414-3445
 U.S.A.
 tel (937) 890-1100
 fax (937) 8905165
 www.pavetechnologyco.com

DESCRIPTION
 SP33/14-AL-150-31-25-M83513

PART NUMBER
5274

MATERIAL NOTED

REVISION LEVEL -

PROJECTION

ALL DIMENSIONS AND TOLERANCES APPLY TO FINISHED PART IN INCHES.
 ALLOWABLE TOLERANCES UNLESS SPECIFIED OTHERWISE: NONE \pm 0.5
 X.X DECIMAL \pm 0.1 X.XX DECIMAL \pm 0.02 X.XXX DECIMAL \pm 0.005
 ANGLES \pm 1 DEGREE SURFACE FINISH 128 microinch RMS