

PIN-OUT TABLE

POS	COLOR	TERMINATION
1	RED	CRIMP
2	BLACK	CRIMP
3	WHITE	SOLDER*
4	GREEN	SOLDER*
5	N/A	DUMMY/PLUG*
6	N/A	DUMMY/PLUG*

*SEE NOTE 4

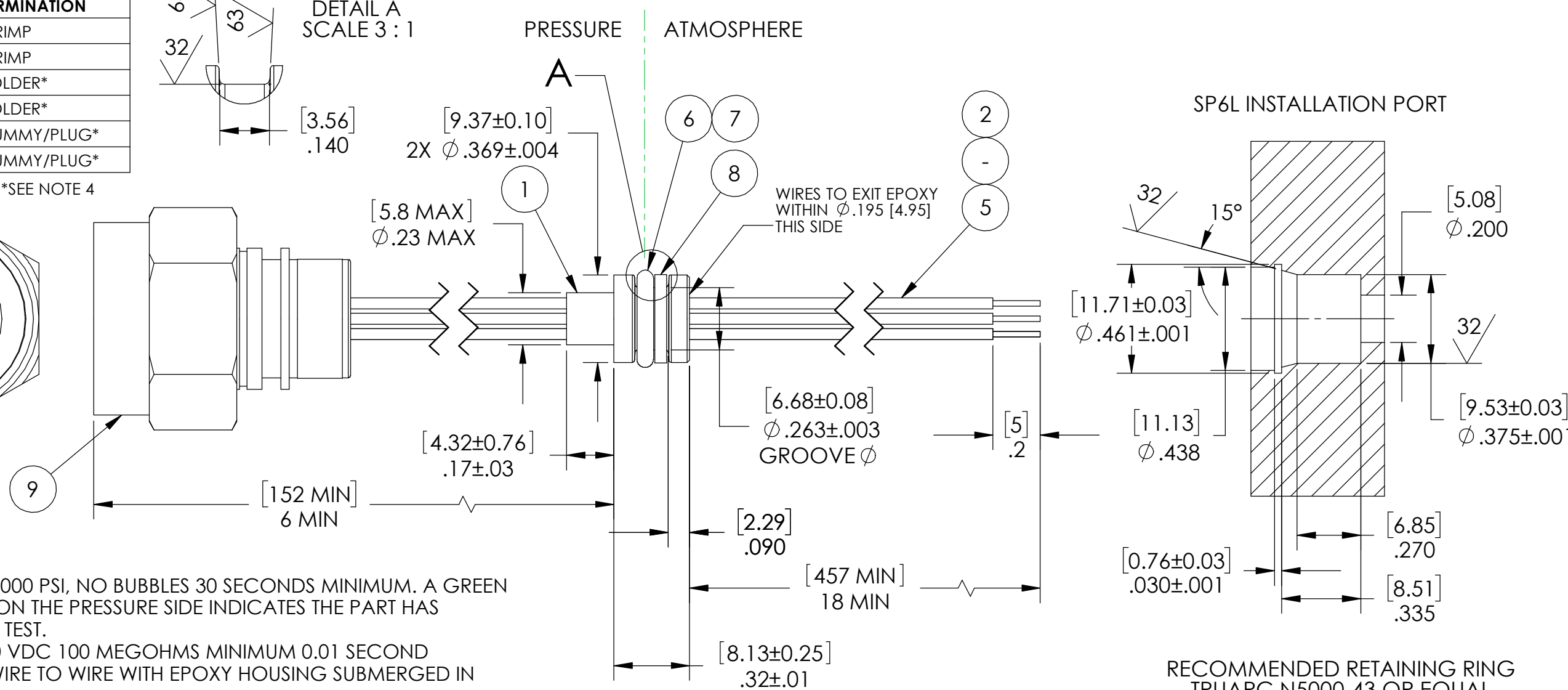
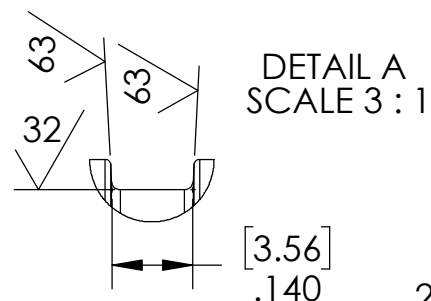
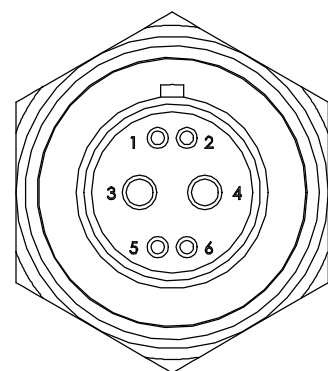

NOTES:

- LEAK TEST: 1000 PSI, NO BUBBLES 30 SECONDS MINIMUM. A GREEN PAINT DOT ON THE PRESSURE SIDE INDICATES THE PART HAS PASSED THE TEST.
- HYPOT 1500 VDC 100 MEGOHMS MINIMUM 0.01 SECOND MINIMUM WIRE TO WIRE WITH EPOXY HOUSING SUBMERGED IN SALT WATER.
- CONTINUITY TEST <0.5 OHM SOCKET TO WIRE END WITH MATING CONNECTOR.
- WIRES ATTACHED TO POSITIONS 3 AND 4 ARE SOLDERED WITH SAC305, EMPTY CONTACTS ARE INSTALLED IN POSITIONS 5 AND 6 AND WILL HAVE GROMMET SEALING PLUGS INSTALLED.
- ALL TESTS ARE PERFORMED AT ROOM TEMPERATURE.
- ALL PARTS MUST PASS ALL TESTS.
- COSMETIC SURFACE VOIDS NOT ON O-RING SEALING SURFACES ARE ACCEPTABLE BASED ON THE SEAL'S DIAMETER:
 <= .5 [12.7] SEAL DIAMETER: Ø.035 [.89] MAX ALLOWED VOID SIZE
 > .5 [12.7] SEAL DIAMETER: Ø.060 [1.5] MAX ALLOWED VOID SIZE
- REF-OPERATING TEMPERATURE RANGE -40°C TO 125°C.
- DIMENSIONS ARE INCHES [millimeters].
- PAVE-SEAL CAN BE A BI-DIRECTIONAL HERMETIC SEAL FOR VACUUM AND MOST PRESSURES. FOR PRESSURES ABOVE 150 PSI (10 BAR), CHECK WITH SALES ENGINEERING.

ITEM	QTY	PART NUMBER	DESCRIPTION
9	1	802-008-06Z19-200SA	PLUG 2#16/4#23 SOCKET SS SHELL, BRONZE COUPLING NUT, EPOXY INSULATOR, GOLD PLATED COPPER ALLOY CONTACTS GLENAIR AQUA MOUSE
8	1	-010 TEFLON	RING -010 TEFLON BACKUP SINGLE TURN SCARF CUT
7	A/R	PARKER O-LUBE	LUBRICANT O-RING BARIUM-BASED
6	1	-010 VITON LT	O-RING -010 VITON 75 LOW TEMP (GLT)
5	1	TZ24 WHT M/16	WIRE 24 TEFZEL M22759/16
4	1	TZ24 RED M/16	WIRE 24 TEFZEL M22759/16
3	1	TZ24 GRN M/16	WIRE 24 TEFZEL M22759/16
2	1	TZ24 BLK M/16	WIRE 24 TEFZEL M22759/16
1	A/R	PAVE-Seal 150	EPOXY BLACK

ALL DIMENSIONS AND TOLERANCES APPLY TO FINISHED PART IN INCHES.
 ALLOWABLE TOLERANCES UNLESS SPECIFIED OTHERWISE: NONE ±0.5
 X.X DECIMAL ±0.1 X.XX DECIMAL ±0.02 X.XXX DECIMAL ±0.005
 ANGLES ±1 DEGREE SURFACE FINISH 128 microinch RMS

PAVE technology co.
 2751 Thunderhawk Court
 Dayton, OH 45414-3445
 U.S.A.
 tel (937) 890-1100
 fax (937) 8905165
 www.pavetechnologyco.com

DESCRIPTION SP6L-E-150-4-TZ24-6T-18	
PART NUMBER 5500	MATERIAL NOTED
REVISION LEVEL -	PROJECTION ☉ ◻