

REF-ASSEMBLY  
SCALE: 2:3

ASSEMBLY SHIPS WITH MAUNFACTURER'S  
PROTECTIVE PLASTIC CAPS INSTALLED

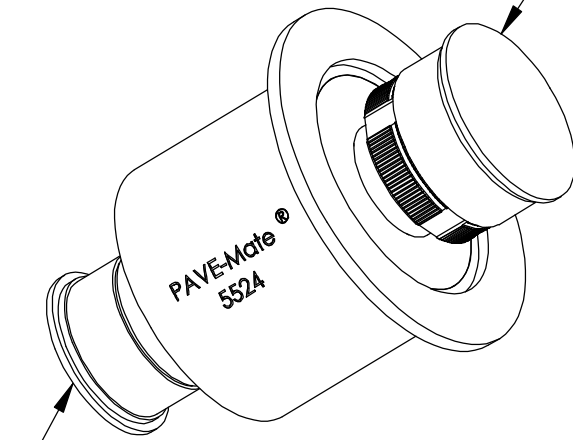

ASSEMBLY SHIPS WITH MAUNFACTURER'S  
PROTECTIVE PLASTIC CAPS INSTALLED

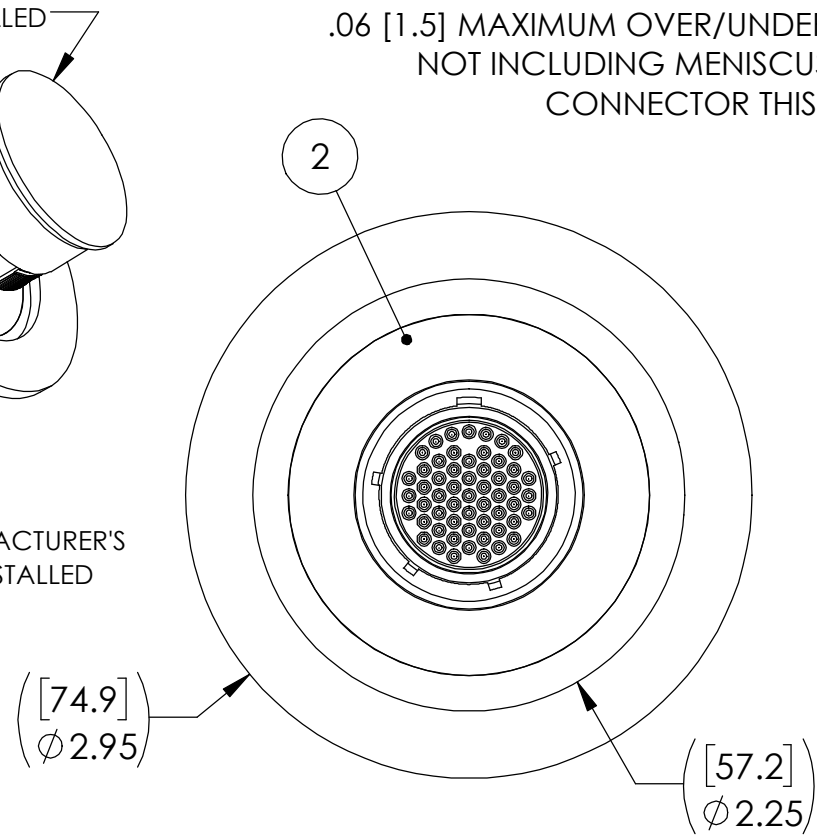

ATMOSPHERE | VACUUM

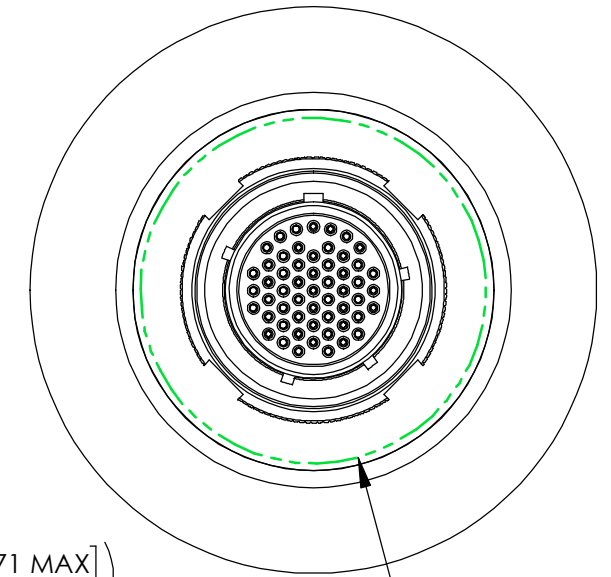
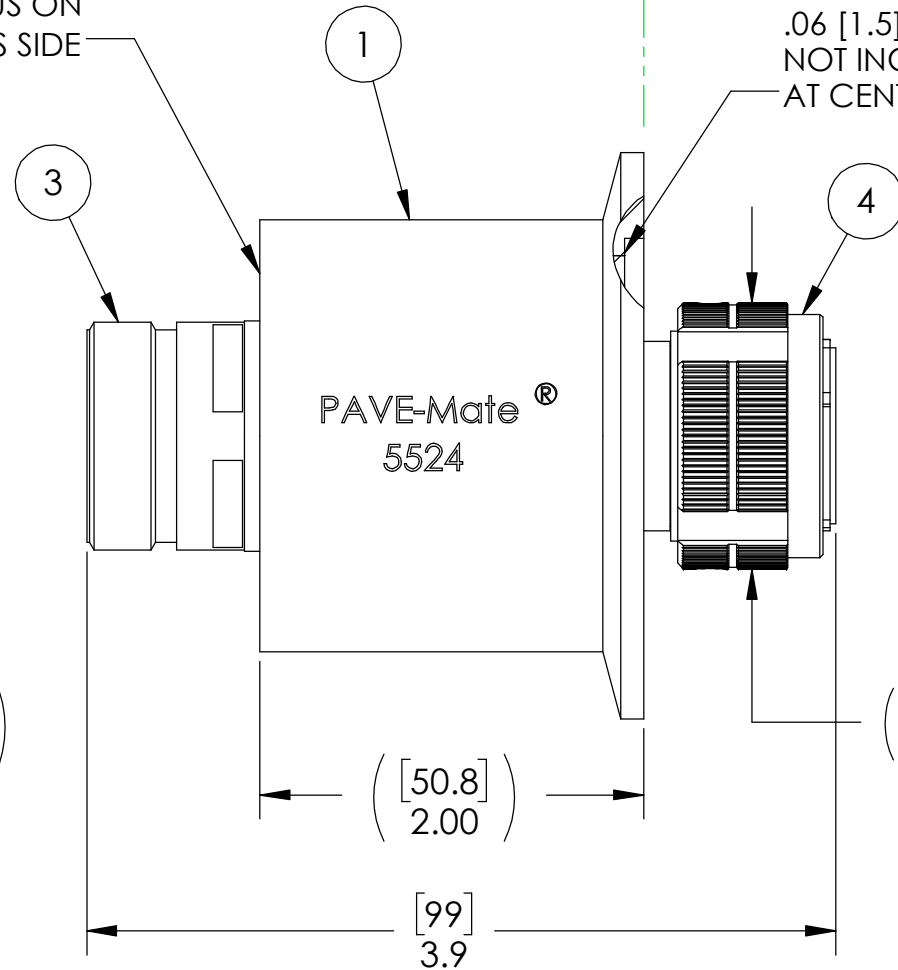

NOTES:

1. HE LEAK TEST @ 1 ATM.  $1 \times 10^{-6}$  CC/SEC OR LESS. A GREEN PAINT DOT ON THE ATMOSPHERE SIDE INDICATES THE PART HAS PASSED THE TEST.
2. HYPOT 1000 VDC 500 MEGOHMS MINIMUM 0.01 SECOND MINIMUM PIN TO PIN AND HOUSING.
3. CONTINUTY TEST <1.0 OHM PIN TO SOCKET WITH MATING CONNECTORS.
4. ALCOHOL OR FOMBLIN YVAC 3 MAY BE USED TO LUBRICATE O-RINGS FOR VACUUM HELIUM LEAK TESTING.
5. ALL TESTS ARE PERFORMED AT ROOM TEMPERATURE.
6. ALL PARTS MUST PASS ALL TESTS.
7. COSMETIC SURFACE VOIDS NOT ON O-RING SEALING SURFACES ARE ACCEPTABLE BASED ON THE SEAL'S DIAMETER:  
 $\leq .5$  [12.7] SEAL DIAMETER:  $\phi .035$  [.89] MAX ALLOWED VOID SIZE  
 $> .5$  [12.7] SEAL DIAMETER:  $\phi .060$  [1.5] MAX ALLOWED VOID SIZE
8. REF-OPERATING TEMPERATURE RANGE  $-20^{\circ}\text{C}$  TO  $125^{\circ}\text{C}$ .
9. DIMENSIONS ARE INCHES [millimeters].
10. PAVE-SEAL CAN BE A BI-DIRECTIONAL HERMETIC SEAL FOR VACUUM AND MOST PRESSURES. FOR PRESSURES ABOVE 150 PSI (10 BAR), CHECK WITH SALES ENGINEERING.

4	1	26FE35SN	PLUG 55#22 SOCKET NICKEL PLATED ALUMINUM SHELL GOLD PLATED COPPER ALLOY CONTACTS
3	1	20FE35PN	RCPT 55#22 PIN NICKEL PLATED ALUMINUM SHELL GOLD PLATED COPPER ALLOY CONTACTS
2	A/R	PAVE-Seal 150	EPOXY BLACK
1	1	4962	HOUSING NW50-SS
ITEM	QTY	PART NUMBER	DESCRIPTION

**PAVE technology co.**

2751 Thunderhawk Court  
Dayton, OH 45414-3445  
U.S.A.  
tel (937) 890-1100  
fax (937) 8905165  
www.pavetechnologyco.com

DESCRIPTION  
NW50-SS-150-55-22-99920/26PS

PART NUMBER

5524

MATERIAL NOTED

REVISION LEVEL -

PROJECTION



ALL DIMENSIONS AND TOLERANCES APPLY TO FINISHED PART IN INCHES.  
ALLOWABLE TOLERANCES UNLESS SPECIFIED OTHERWISE: NONE  $\pm 0.5$   
X.X DECIMAL  $\pm 0.1$  X.XX DECIMAL  $\pm 0.02$  X.XXX DECIMAL  $\pm 0.005$   
ANGLES  $\pm 1$  DEGREE SURFACE FINISH 128 microinch RMS