

RECOMMENDED RETAINING RING
TRUARC N5000-43 OR EQUAL

ADDITIONAL HOUSING DETAILS
(O-RINGS & BACKUP RING REMOVED FOR CLARITY)

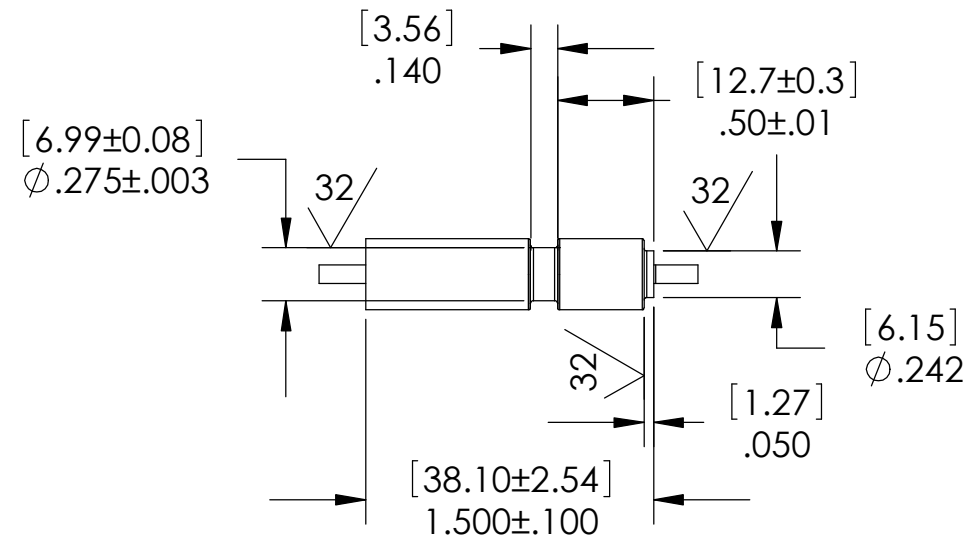

NOTES:

1. LEAK TEST: 800 PSI, NO N2 BUBBLES 30 SECONDS MINIMUM. A GREEN PAINT DOT ON THE PRESSURE SIDE INDICATES THE PART HAS PASSED THE TEST.
2. HYPOT 630 VDC 500 MEGOHMS MINIMUM 0.01 SECOND MINIMUM CENTER CONDUCTOR TO SHIELD.
3. CONTINUITY TEST SHIELD <0.5 OHM END TO END.
4. ALL TESTS ARE PERFORMED AT ROOM TEMPERATURE.
5. ALL PARTS MUST PASS ALL TESTS.
6. WIRE POSITIONING IS APPROXIMATE & VARIABLE.
7. COSMETIC SURFACE VOIDS NOT ON O-RING SEALING SURFACES ARE ACCEPTABLE BASED ON THE SEAL'S DIAMETER:
 <= .5 [12.7] SEAL DIAMETER: ϕ .035 [.89] MAX ALLOWED VOID SIZE
 > .5 [12.7] SEAL DIAMETER: ϕ .060 [1.5] MAX ALLOWED VOID SIZE
8. REF-OPERATING TEMPERATURE RANGE -20 °C TO 125 °C.
9. DIMENSIONS ARE INCHES [millimeters].
10. PAVE-SEAL CAN BE A BI-DIRECTIONAL HERMETIC SEAL FOR VACUUM AND MOST PRESSURES. FOR PRESSURES ABOVE 150 PSI (10 BAR), CHECK WITH SALES ENGINEERING.

5	A/R	PARKER O-LUBE	LUBRICANT O-RING BARIUM-BASED
4	1	B/U RING -010	BACK UP RING -010 SINGLE TURN PER MS28774
3	2	-010 VITON	O-RING -010 VITON 75
2	1	RG316	CABLE COAX BELDEN B83284 OR EQUAL
1	A/R	PAVE-Seal 150	EPOXY BLACK
ITEM	QTY	PART NUMBER	DESCRIPTION

2751 Thunderhawk Court
Dayton, OH 45414-3445
U.S.A.
tel (937) 890-1100
fax (937) 8905165
www.pavetechnologyco.com

PAVE technology co.

DESCRIPTION
SP6H-E-150-1-RG316-18-18

PART NUMBER
5752

MATERIAL NOTED

REVISION LEVEL -

PROJECTION

ALL DIMENSIONS AND TOLERANCES APPLY TO FINISHED PART IN INCHES.
 ALLOWABLE TOLERANCES UNLESS SPECIFIED OTHERWISE: NONE ±0.5
 XX DECIMAL ±0.1 X.XX DECIMAL ±0.02 X.XXX DECIMAL ±0.005
 ANGLES ±1 DEGREE SURFACE FINISH 128 microinch RMS