

SPF12 INSTALLATION PORT

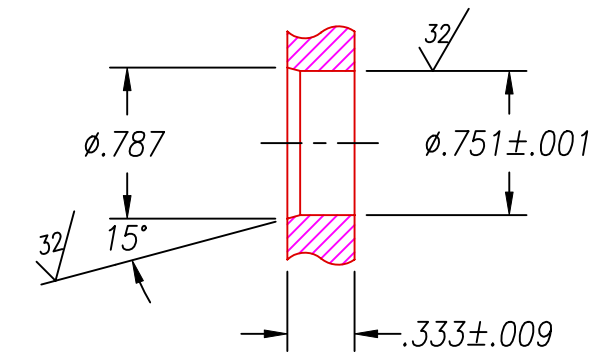

RECOMMENDED RETAINING RING
TRUARC #5100-75 OR EQUAL

NOTES:

1. HE LEAK TEST @1 ATM. 10×10^{-8} CC/S OR LESS. CLEAN O-RING WITH METHANOL BEFORE INSERTING INTO TEST PORT.
2. 30 KVDC HYPOT TEST WITH 5 μ A MAXIMUM LEAKAGE TO LEAK TEST PORT.
3. ALL TESTS ARE DONE AT ROOM TEMPERATURE & HUMIDITY.
4. ALL PARTS MUST PASS ALL TESTS.
5. O-RING TO BE SHIPPED DRY, NO O-LUBE ALLOWED.
6. CONTINUOUS CONTACT OF METHANOL TO VITON O-RING WILL CAUSE O-RING TO SWELL AND NOT SEAL PROPERLY.
7. "PAVE" & "2813" MARKINGS APPROXIMATELY AS SHOWN.
8. NO VOIDS ARE ACCEPTABLE ON O-RING SEALING SURFACES, VOIDS SMALLER THAN $\phi.035$ ARE ACCEPTABLE ON ALL OTHER SURFACES.
9. CONTINUITY TEST < 40 m Ω END OF TERMINAL TO END OF MATING CONNECTOR.
10. LABEL W/"RAD MIRROR #2", "1016844/D", "PAV".
11. LABEL W/INFORMATION SPECIFIED, ALL LABELS TO BE INSTALLED SO THAT ALL INFORMATION ON LABEL IS VISIBLE.
12. PACKAGE ASSEMBLY INDIVIDUALLY IN A PLASTIC BAG AND INCLUDE "1016844 REV:D" ON BAG LABEL.
13. REF-PARTS ARE DEFLASHED ON PARTING LINE +.005 MAXIMUM.

9	1	SHS-450-4012BLK	TUBING SHRINK HEAT .450" ID BLACK
8	1	CRS-TO-2202	TERMINAL RING #2 26-24 AWG
7	2	-	PRINTABLE LABEL
6	A/R	PAVE-Seal 150	EPOXY BLUE
5	1	-016 VITON	O-RING -016 VITON 75
4	1	UPCSCI#1521 ORL	TUBING FEP 1/16"ID X 1/8"OD
3	1	TIN COPPER #20	WIRE BUS #20 TINNED
2	1	0130	HOUSING SPF12-E
1	1	ALDEN #B200PA48	BELDEN 9867 W/ALDEN B200-200
ITEM	QTY	PART#	DESCRIPTION

ALL DIMENSIONS AND TOLERANCES APPLY TO FINISHED PART IN INCHES
 ALLOWABLE TOLERANCES UNLESS SPECIFIED OTHERWISE: NONE +/-0.5
 .X DECIMAL +/- 0.1 .XX DECIMAL +/- 0.02 .XXX DECIMAL +/-0.005
 ANGLES +/- 1 DEG SURFACE FINISH 128 microinch RMS

2751 Thunderhawk Court
Dayton, Ohio 45414-3445
U.S.A.
(937)890-1100
fax (937)890-5165
www.pavetechnologyco.com

PAVE technology co.

DESCRIPTION PAVE-Seal Cable Harnesses
SPF12-E-150-1-B200PA48/BUS20-27-11

PART NUMBER **2813**

REVISION LEVEL **D**

PROJECTION